

# PX-6700/6750

## 03 type

# Operation Manual

---

PX-6700 2-sheet thermal printer

PX-6750 1-sheet thermal printer

---

THE SOCKET-OUTLET SHALL BE INSTALLED NEAR THE EQUIPMENT AND SHALL BE EASILY ACCESSIBLE.

LA PRISE DOIT ETRE PRES DE L'APPAREIL ET FACILE D'ACCES.

Note: This equipment has been tested and found to comply with the limits for a Class B digital device, pursuant to part 15 of the FCC Rules. These limits are designed to provide reasonable protection against harmful interference in a residential installation. This equipment generates, uses and can radiate radio frequency energy and, if not installed and used in accordance with the instructions, may cause harmful interference to radio communications. However, there is no guarantee that interference will not occur in a particular installation. If this equipment does cause harmful interference to radio or television reception, which can be determined by turning the equipment off and on, the user is encouraged to try to correct the interference by one or more of the following measures:

- Reorient or relocate the receiving antenna.
- Increase the separation between the equipment and receiver.
- Connect the equipment into an outlet on a circuit different from that to which the receiver is connected.
- Consult the dealer or an experienced radio/TV technician for help.

# CONTENTS

<b>ATTENTION</b> .....	<b>1</b>
<b>I. INTRODUCTION</b> .....	<b>2</b>
<b>II. INSTALLATION</b> .....	<b>3</b>
Replacing paper rolls for 2-sheet thermal printer.....	4
Attentions for 2-sheet thermal printer.....	5
Replacing paper rolls for 1-sheet thermal printer.....	6
In case that the Auto-Cutter on 1-sheet thermal printer does not return.....	7
<b>III. DISPLAY</b> .....	<b>8</b>
<b>IV. STANDARD KEY LAYOUT</b> .....	<b>9</b>
<b>V. KEY EXPLANATION</b> .....	<b>11</b>
<b>VI. OPERATION SEQUENCES</b> .....	<b>16</b>
1. Clerk Time-in / Time-out (optional memory board required).....	16
2. Clerk Sign-on / Sign-off.....	17
3. Clerk Interrupt System.....	18
4. Floating Clerk Interrupt.....	20
5. PLU.....	22
a) Manual Price Entry.....	23
b) Repetition.....	23
c) Multiplication.....	24
d) Split Pricing.....	25
e) Square Entry (Measurement Calculation).....	25
f) Price Shift.....	26
g) Menu Shift.....	26
h) Link PLU.....	27
i) Simple Condiment PLU.....	28
j) PLU Modifier.....	29
k) Single Item.....	30
l) Cooking Message & PLU Supplementary Message.....	31
m) Sales by Weight.....	32
n) Simple Look Up PLU.....	38
6. Kitchen Printer.....	39
7. Media Closing.....	43
8. Tray Subtotal.....	44
9. Foreign Currency / Euro Currency.....	45
a) Closing Methods.....	45
b) Currency Exchange.....	46
c) Euro Currency System.....	46
10. Cheque Cashing / Cheque Printing.....	48
a) Cheque Cashing.....	48
b) Cheque Printing on Slip Printer (TP-620).....	48
11. Tip Operation.....	49
a) Tip Amount Input.....	49
b) Change Kept As Tip.....	49
12. Mark-up / Mark-down.....	50
13. Adjustment (Automatic % on Specific Items).....	51
14. Amount Plus / Amount Discount.....	52
15. Last Item Correction.....	52
16. Void / Scroll Void.....	53
17. Transaction Void.....	56
18. Refund / Media Refund.....	57
19. Tax.....	60
20. R/A (Received on Account).....	63
21. P/O (Paid Out).....	63
22. No Sale.....	64

23. Off Compulsory .....	64
24. Number of People .....	65
25. Message .....	66
26. Slip Validation (TP-620 only).....	67
27. Arrangement .....	68
28. Recall .....	69
29. Track System - Item Track / Amount Track .....	70
• Two Track Systems --- Item and Amount Track Systems can be used at the same time .....	70
• Two Track Number Entry Methods.....	71
• Clerk Track Assignment Methods (Item Track System Only).....	72
• Note for Item / Amount Track System used with Clerk Interrupt System .....	72
• Track Operation Sequences .....	73
A. Item Track System.....	74
a) Opening a New Track & Closing Temporarily.....	74
b) Picking Up a Track & Closing a Track Finally .....	77
c) Table # Assigned to an Item Track.....	80
d) Track Transfer to a New Track or a Designated Track [SF-15.b=1] .....	82
e) Item Transfer to Item Track in Scroll Display Mode.....	83
f) Item Track Transfer to Amount Track (optional memory board required) .....	86
g) Item Track Balance Calculation (display only).....	87
B. Amount Track System (optional memory board required) .....	88
30. Floating Item Track / Floating Amount Track .....	91
31. Previous Balance Plus (PB+) / Previous Balance Minus (PB-) .....	94
32. Ticket System.....	95
a) Real-Time Ticket Sample.....	96
b) After Closing Ticket Sample.....	97
c) Mixed Ticket Sample (two kinds of combined ticket).....	98
d) Multiple Ticket Sample.....	99
e) Other Notes for Ticket.....	100
33. Customer File.....	101
a) New Customer File Making in R or SP Position .....	102
b) Customer File Editing in SP Position.....	102
c) Customer File Deleting in SP Position .....	102
d) Customer File Pick-Up Sequence .....	102
34. ESF Data Print (optional memory board required) .....	105
35. Cash Declaration.....	107
<b>VII. TRAINING.....</b>	<b>108</b>
<b>VIII. PRINT CONTENTS.....</b>	<b>110</b>
1. Journal Print Contents .....	110
2. Receipt / Slip Print Contents .....	110
3. Post-Receipt .....	110
<b>IX. REPORTS .....</b>	<b>111</b>
REPORT SEQUENCE.....	111
IRC REPORT SEQUENCE .....	115
FLASH IRC REPORTS .....	117
TRANSACTION REPORT SAMPLES.....	118
<b>X. WARNING MESSAGES.....</b>	<b>129</b>
<b>XI. IRC MESSAGES .....</b>	<b>133</b>

## Notes

1. The contents of this manual are subject to change without notice.
2. We can not be held responsible if other products, which are not approved by us, are used for options or expendable supplies.

## ***ATTENTION***

---

Thank you very much for purchasing this Electronic Cash Registers. This ECR has many programmable features, hardware combinations and options. Please consult your dealer as to your particular requirements, as this ECR can be configured, through both hardware and software (programming) to suit a variety of different applications.

Please fill in the information requested below:

MODEL :

---

SERIAL No.:

---

DATE OF PURCHASE:

---

YOUR DEALER  
(WHERE PURCHASED):

---

Phone/Fax/Address:

---

---

---

# ***I. INTRODUCTION***

---

This ECR is Hospitality POS terminals for Restaurants, Bars / Pubs and Quick Service having a lot of functions like scanning system, clerk interrupt system and Inter Register Communication, and so on as follows:

## **Major Features**

- Wide LCD display (40 digits, 8 lines) with scroll functions
- High speed thermal printer
- Scanning system with 14 digits random PLU code having 22 digits PLU descriptor
- Standard 780 PLUs, Max. 36148 PLUs (option)
- 98 group-As with stock control, 25 group-Bs and 10 main group-As
- 40 Look Up PLU keys, up to 40 PLUs assigned to one Look Up PLU key
- 64 clerks with its own full transaction memory
- Clerk interrupt system including IRC floating clerk
- Clerk time & attendance - 3780 records (option)
- Clerk report with specified 20 PLUs or 20 group-As sales data or optional 1000 PLUs
- Clerk iButton (option)
- Customer bill buffer records check-out bill contents excluding PLU contents (option)
- 1024 customer files make records of telephone number or VAT number, name and address - these information are issued on the bills for delivery service market, etc. (option)
- Item track system and amount track system (option) including IRC floating tracks
- Scroll Void
- Transaction Void
- Item Transfer to an Item Track
- Simple Condiment PLU
- Euro Currency System
- Tray Subtotal Tendering
- ESF buffer print with max. 15887 records of ESF memory (option)
- Ticketing Function
- 25 Media Keys + 10 Preset Tender Keys
- 10 Arrangement Keys (50 key steps)
- Card functions - Clerk sign on by card, Arrangement card, Amount track card, Adjustment card, Card payment including real-time card verification with a PC via IRC line
- PC Batch Communication, Programming Module PLM 2000
- IRC (Inter Register Communication)
  - 32 ECRs
  - flash reports and flash downloading from PC as IRC master (Tensai2000)
  - floating clerk, floating track
  - 8 kitchen printers TP-822/832, CBM-1000 via NA-710/730
  - 8 slip printers TP-620, one of KP can be used as slip printer
  - PC communications with Tensai2000
- Scale link

## II. INSTALLATION

---

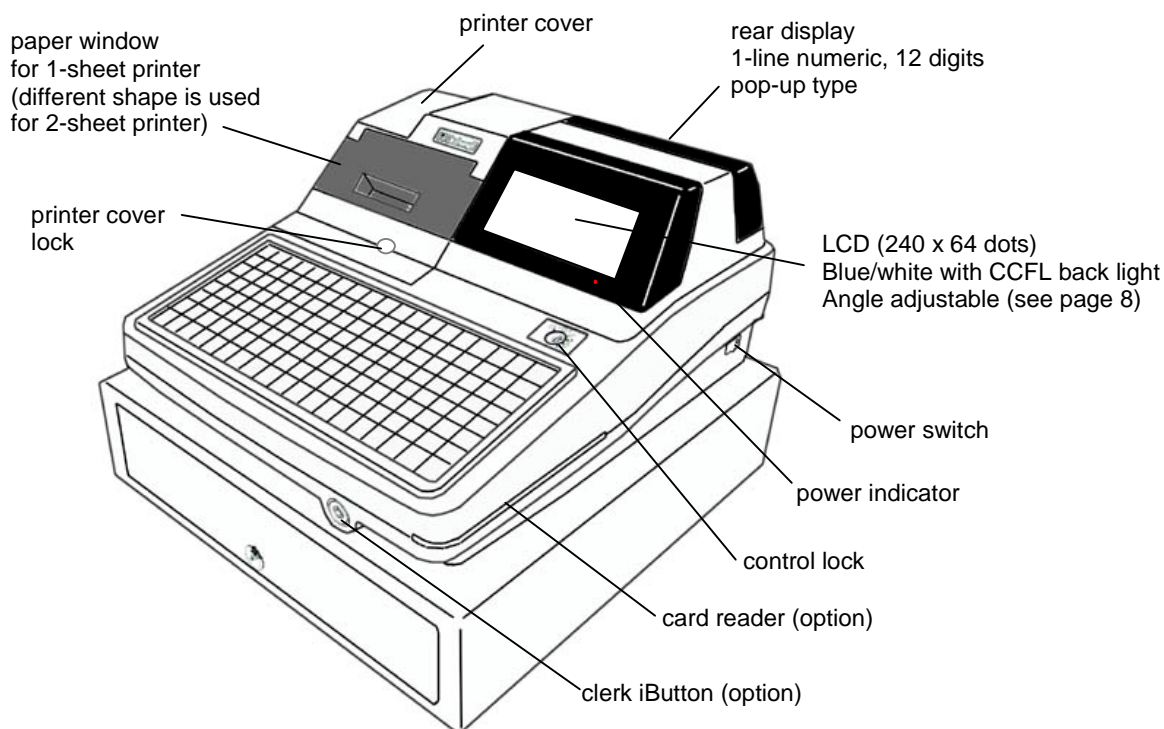

### Unpacking

Check the contents for obvious physical damage.

### Suggestions for installation

- 1) The ECR should not be installed in extremely hot or cold places, or places which are exposed to direct sunlight for extended periods of time.
- 2) The ECR should not be installed where it may come into contact with excessive dust.
- 3) The ECR should not come into contact with liquid.

### Check the following before using ECR

- 1) The required peripheral(s) has (have) been connected to the correct interface connector(s);
- 2) The power plug is connected to the AC outlet;
- 3) The control key is turned to the appropriate position;
- 4) The appropriate number of paper roll(s) is (are) fitted.

**When you connect / disconnect the cable for the peripheral, make sure that the power is "OFF".**

## Replacing paper rolls for 2-sheet thermal printer

- Turn the printer cover lock key counter-clockwise and gently lift the printer cover.
- Remove the old paper:**  
Press the receipt paper feed or journal paper feed key to feed the remaining paper through the printer,  
Or pull the platen open lever, open the paper roll cover and remove the remaining paper. (When you open the paper roll cover, continuous buzzer sounds.)  
**DO NOT** force paper through the printer as this may result in damage to the printer mechanism or cause a paper jam.
- Inserting new paper:**  
Place the new paper in the correct position on the printer's paper roll bed.

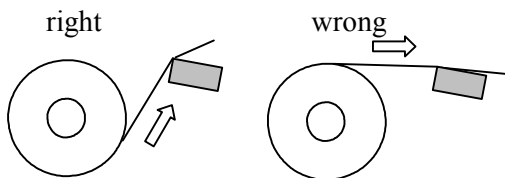

- Close the paper roll cover by pressing down the surbased point. In the case of the receipt paper, the leading edge of the paper is cut automatically.
- In the case of the journal paper, insert the loose end of the paper tightly to the slot of journal 'take-up' spool.

fine quality thermal paper roll  
57.5 +/- 0.5 mm x ø83 mm

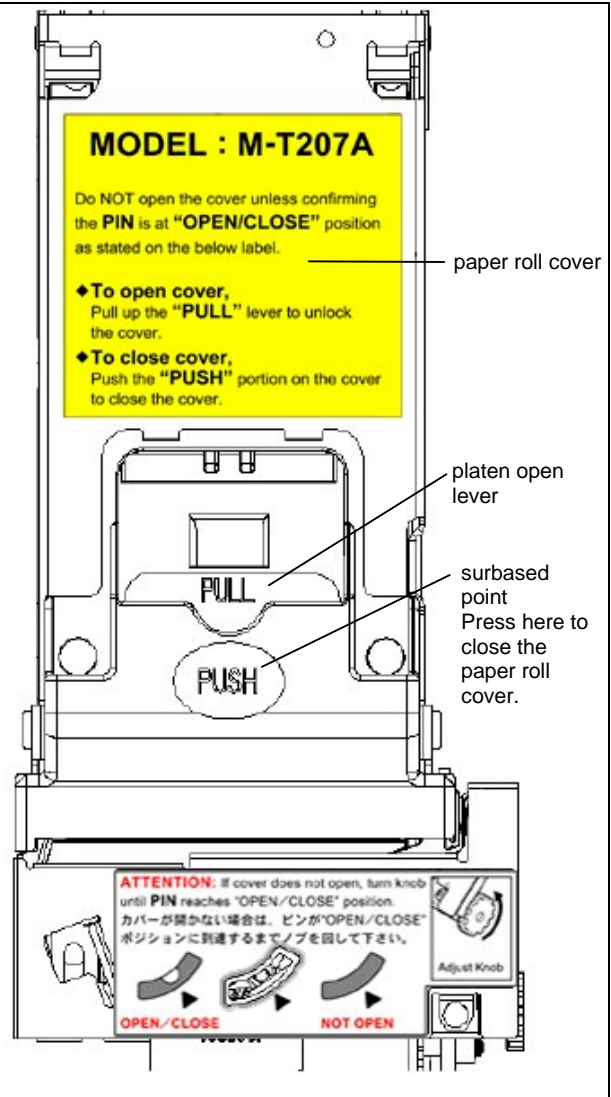

### < When receipt paper jammed inside the paper guide >

- Check the PIN position is in the OPEN/CLOSE position.  
If it is not, use the knob to return it to the OPEN/CLOSE position in order to return the cutter blade to the standby position.
- Cut the jammed paper at paper entrance.
- Remove the jammed paper straight from the paper exit.

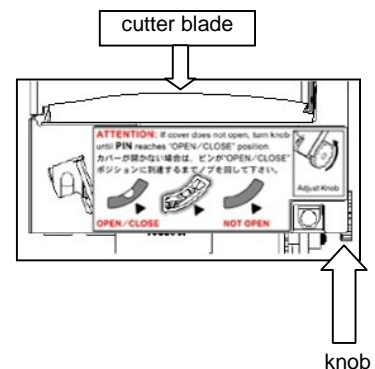

### ***Attentions for 2-sheet thermal printer***

In order to use thermal receipt printer comfortably, pay attention to the following points:

- **Thermal Paper**

Please use a designated **fine quality thermal paper roll**:

Paper type	Single roll thermal paper
Recommended	KF50 (KANZAN) TF50KS-E (Nippon Paper Industries) P350 (KSP)
Paper size	57.5 +/- 0.5 mm less than ø83 mm thickness 60~75 µm

- **Paper Cut**

Do not pull the receipt until the completion of receipt issue.

Cut the paper by pulling to the left or front side because there is a remaining breaking point on the left end of the paper.

- **In case that Paper Jam happens**

Even if a receipt paper is somehow jammed, you can remove the paper swiftly and easily because of its cram shell mechanism. See the steps on the previous page.

## Replacing paper rolls for 1-sheet thermal printer

a) Turn the printer cover lock key counter-clockwise and gently lift the printer cover.

b) **Remove the old paper:**  
Press the paper feed key to feed the remaining paper through the printer. **DO NOT** force paper through the printer as this may result in damage to the printer mechanism or cause a paper jam.

OR

Pull the head up lever towards the front of ECR and pull the paper through the printer.

c) **Inserting new paper:**  
Using the scissors, cut the leading edge of the paper roll **straight**.

Insert the paper shaft through the core of the new paper roll.

Place the new paper in the **correct position** on the printer's paper roll bed.

Set the head up lever to the head down condition.

Insert the leading edge of the paper to the paper inlet. The paper is automatically loaded under the power switch on condition.

fine quality thermal paper roll  
TF50KS-E2C (Nippon Paper Industries)  
80 mm x ø80 mm

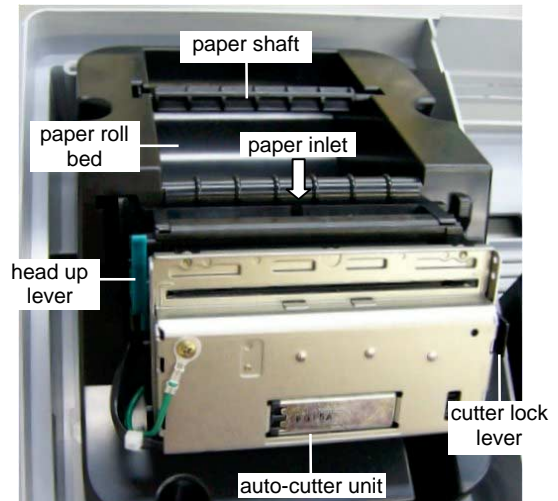
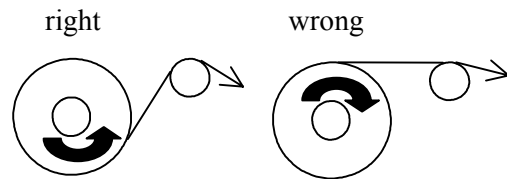

### < When receipt paper jammed inside the paper guide >

1. Raise the auto paper cutter unit by pulling cutter lock lever.
2. Remove the jammed paper by hand.
3. Close the auto cutter unit.

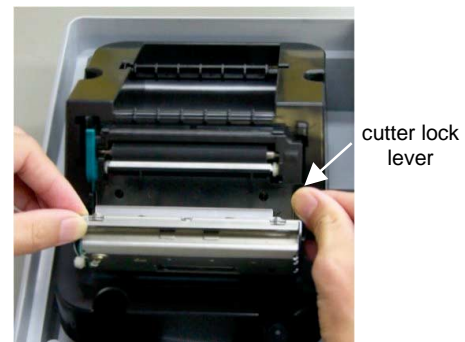

### ***In case that the Auto-Cutter on 1-sheet thermal printer does not return***

If the auto-cutter is locked by a paper jam or if something come into the auto-cutter and locked, please follow the sequences below:

- a) Turn the power switch off. Open the printer cover.
- b) Pull the cutter lock lever to right and pull the auto-cutter unit.
- c) Turn the emergency knob in order to draw in the cutter to the direction that the arrow shows.
- d) Then, remove the paper or the something.

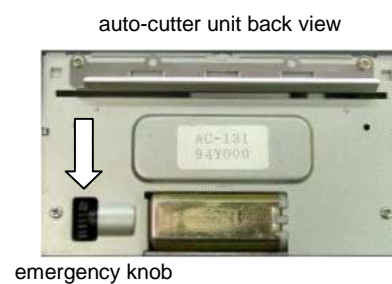
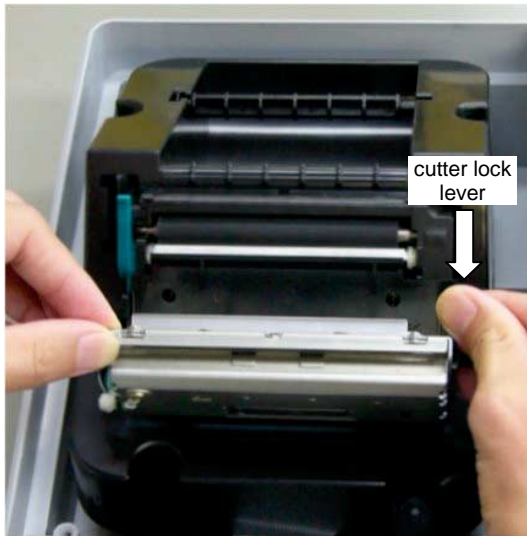

**Do not touch the print head by hand right after printing since it is very hot.**

### III. DISPLAY

#### FRONT LCD DISPLAY



Display type	64 (H) x 240 (W) dot matrix
Dot size	0.46 (H) x 0.41 (W) mm/dot
View area	38 (H) x 116 (W) mm
LCD type	STN Blue mode, transmissive
Back light	white CCFL back light

#### Reversing function, Small PLU display [SF-119.g,h]

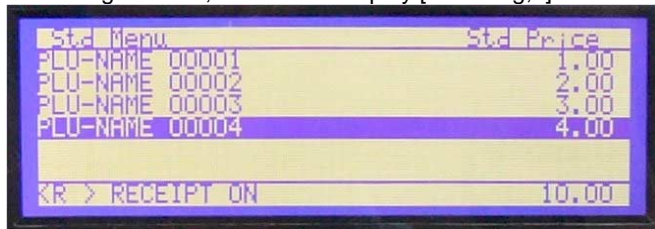

#### How to Adjust Contrast

Contrast on the display can be adjusted by **SCROLL UP/ DOWN** key (**PAGE UP/DOWN** key for more dynamic adjustment) when no item entered in R position or Warn Message# 03 (Clerk Sign-off) is displayed in other positions. Press **CLERK ID** key two times for clerk sign-off.



#### How to Adjust Angle

Three angles are available.

1. Open printer cover.
2. Insert a minus driver into a hole of LCD cover.
3. Adjust angle by using a minus driver.

#### REAR DISPLAY

12 digits numeric (7 segments/digit)

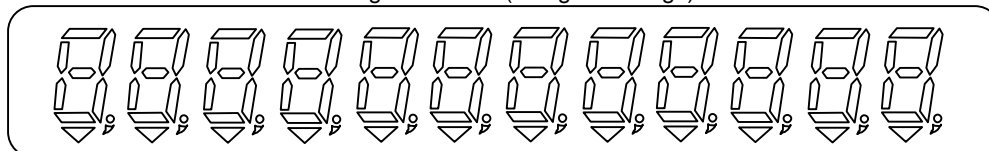

REG    2nd    2nd    3rd    #    %    +/-    VD    PO    R-OFF    TOTAL  
          PRICE    MENU    MENU              RF    RA

These captions are not indicated.

# IV. STANDARD KEY LAYOUT

## Stroke Keyboard

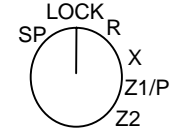

↑ RPF	↑ JPF	RECEIPT OFF	(Fix/Pgm)	A 1	G 7	M 13	S 19	Y 25		€ CLERK 1	£ CLERK 2	: CLERK 3	@ CLERK 4	(BS) CLERK 5
CL	X2/FOR TIME	CLERK ID	(L/R)	B 2	H 8	N 14	T 20	Z 26		# PLU REPEAT	Ñ PRICE	Ø CR	? VOID	(SPACE) REFUND
7	8	9	(INS SP)	C 3	I 9	O 15	U 21	Ä 27		\$ %1	* %2	< (-)	(A/C) P/O	(CAPS) R/A
4	5	6	←	D 4	J 10	P 16	V 22	Ö 28		% MESSAGE	Å BUFFER PRINT 1	Σ SBTL		(SMALL) TTL 1 TTL 2
1	2	3	→	E 5	K 11	Q 17	W 23	Û 29		& PAGE UP	- ↑ SCROLL	> NO SALE		(DOUBLE) TTL 3 TTL 4
0	00	•	(DEL)	F 6	L 12	R 18	X 24	Æ 30		° PAGE DOWN	/ SCROLL ↓	ENTER	(ENTER)	CASH/TTL25

option

Control key position range: There are three standard control keys (M, Z, X).

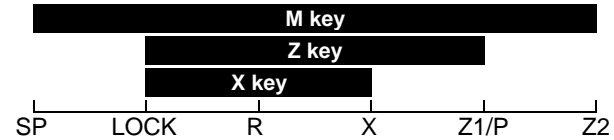

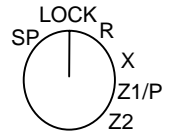

## Flat Keyboard

1	9	17	25	33	41	49	57	65	73	81	89	97	105	↑ RPF	↑ JPF	RECEIPT OFF	BUFFER PRINT 1	CLERK 1
2	10	18	26	34	42	50	58	66	74	82	90	98	106	PAGE UP	↑ SCROLL	REFUND	VOID	CLERK 2
3	11	@	#	\$	%	Æ	&	*	£	Ñ	Á	-	Ø	PAGE DOWN	SCROLL ↓	ENTER	CR	CLERK 3
4	12	20	28	36	44	52	60	68	76	84	92	100	108	CL	X2/FOR TIME	CLERK ID	PLU REPEAT	TTL 1
(Fix/Pgm)	Q	W	E	R	T	Y	U	I	O	P	Ö	Ü	.	7	8	9	PRICE SHIFT	TTL 2
5	13	21	29	37	45	53	61	69	77	85	93	101	109	4	5	6	%1	TTL 3
(L/R)	A	S	D	F	G	H	J	K	L	:	,	/	←	6	5	6	%1	TTL 3
6	14	22	30	38	46	54	62	70	78	86	94	102	110	1	2	3	NO SALE	TTL 4
(INS SP)	(A/C)	Z	X	C	V	B	N	M	<	>	?	(BACK SP)		1	2	3	NO SALE	TTL 4
7	15	23	31	39	47	55	63	71	79	87	95	103	111	0	00	•	SBTL	(ENTER)
(DEL)	(CAPS)	(SMALL)		(SPACE)	(SPACE)	→		(DOUBLE)		(CL)			(ENTER)	0	00	•	SBTL	CASH TTL 25
8	16	24	32	40	48	56	64	72	80	88	96	104	112					

## V. KEY EXPLANATION

Page	Key	Remarks
51	ADJUSTMENT 1, 2, 1 & 2	Automatic % Discount/Surcharge on Specific Items: Calculates mark-up or mark-down on the subtotal amount of items which have been preprogrammed as one of adjustable 1, 2 or 1 & 2 item. Note that adjustment does not affect PLU sales memory which is shown on the reports.
52	AMOUNT (-)	Subtracts an amount from the item or subtotal depending on the operation. It is possible to register a preset amount or to override it manually.
52	AMOUNT (+)	Adds an amount to the item or subtotal amount depending on the operation. It is possible to register a preset amount or to override it manually.
88	AMOUNT TRACK #	<ul style="list-style-type: none"> <li>- Assigns a new Amount Track. Enter random 7 digits track number and press this key.</li> <li>- Picks up the temporarily closed Amount Track. Enter a track number and press this key.</li> <li>- Displays an Amount Track number in Scroll Display Mode if it has been entered.</li> </ul>
68	ARRANGEMENT 1 ~ 10	Performs sequences of programmed steps (up to 50-key steps). Useful for 1-key operations such as fixed sales or report-takes.
87	BALANCE CALCULATION	Shows the balance and calculates the total of multiple tracks and displays their combined total. Also the balance can be divided; for example, between the number of customers.
77	BILL CANCEL	Releases the compulsory condition of a check-out bill issue for an Item Track.
110	BUFFER PRINT 1, 2	<ul style="list-style-type: none"> <li>- <b>BUFFER PRINT 1</b> key prints a post-receipt / bill (only the lastly registered contents) including VAT data on a receipt in the receipt-off condition or on a slip when the ECR is programmed for use with a slip printer.</li> <li>- <b>BUFFER PRINT 2</b> key prints a post-receipt / bill without VAT data. However, the add-on tax data is printed.</li> <li>- These keys are used to print an Item Confirmation Receipt in Clerk Interrupt System.</li> <li>- The second receipt issue by these keys is available by programming when the ECR is not programmed for use with a slip printer.</li> <li>- Used for the manual line finder when the pre-feed line number is entered when using a slip printer.</li> </ul>
88	CHARGE for Amount Track System	<ul style="list-style-type: none"> <li>- Temporarily closes an Amount Track and saves the amount in Charge memory.</li> <li>- Used for Amount Track Transfer and Track Consolidation in Floating Amount Track System.</li> </ul>
77	CHECK-OUT BILL 1 ~ 3 for Item Track System	<ul style="list-style-type: none"> <li>- <b>CHECK-OUT BILL 1</b> key prints the check-out bill with VAT data.</li> <li>- <b>CHECK-OUT BILL 2</b> key prints the check-out bill without VAT data.</li> <li>- <b>CHECK-OUT BILL 3</b> key prints the check-out bill with VAT data (thermal printer only). If "without slip printer" has been set, the check-out bill on receipt will have German Declaration Form for the law of German restaurant.</li> <li>- These keys print the subtotal bill with or without VAT data when the Item Track number is entered or immediately after the Item Track is closed by <b>NB</b> (New Balance) key.</li> </ul>
	CL (Clear)	Cancels any information that is entered by ten-key or function key (P/O, R/A, tax shift, etc.) before registration; also clears error conditions.
17	HARD CLERK 1 ~ 15	<ul style="list-style-type: none"> <li>- Signs a clerk on or off without the clerk code entry.</li> <li>- Interrupts a clerk when another clerk signs on in Clerk Interrupt System.</li> </ul>
17	CLERK ID	Used for clerk sign-on and sign-off when using the secret clerk code system for entry into registration.

17	CLERK iBUTTON (option)	Used for clerk sign-on and sign-off when using Clerk iButton for entry into registration by [SF-12.h]. This can not be used in Clerk Interrupt System. If so programmed by [SF-12.f] and when the clerk iButton is removed, the transaction is automatically closed by <b>CASH/TTL 25</b> key, Item Track is automatically closed by <b>NB</b> key and Amount Track is automatically closed by <b>CHARGE</b> key.
31	COOKING MESSAGE for manual entry	<ul style="list-style-type: none"> <li>- Enters one of supplementary messages 1 ~ 50 as a cooking message prior to a PLU entry. If a number greater than 50 is entered, then the number will be printed.</li> <li>- Enters a cooking message (20 digits) manually prior to a PLU entry. Use the alphabet keys and <b>ENTER</b> key to enter the message.</li> </ul>
31	HARD COOKING MESSAGE 1 ~ 5 for one-touch entry	Registers one of supplementary messages 1 ~ 5 as a cooking message prior to a PLU entry. <b>Hard Cooking Message 1</b> key picks up supplementary message #1, <b>Hard Cooking Message 2</b> key picks up supplementary message #2 and so on.
52	CR (Correction)	Cancels the registration of the last-registered item including function key inputs such as %, amount (-), scroll void, etc.
101	CUSTOMER FILE	Used for making or picking up a customer file.
	ENTER	Used to fix the selection.
105	ESF PRINT	Prints ESF data on the receipt in the <b>R</b> or <b>X</b> control key position.
45	F.C. SBTL (Foreign Currency Subtotal)	Displays the subtotal of the foreign currency by the depressions of <b>F.C. SBTL</b> key and the foreign currency media key. The subtotal of foreign currency must be displayed whenever the tendering amount in the foreign currency is entered.
	HALO RELEASE	Releases PLU HALO (High Amount Lock-Out) and compulsory condition of PLU stock input.
74	ITEM TRACK #	<ul style="list-style-type: none"> <li>- Assigns a new Item Track. One of Manual or Automatic Item Track # method is used. <b>Manual Item Track # method</b> Enter random 7 digits Item Track number and press this key. <b>Automatic Item Track # method</b> Item Track number is automatically assigned immediately after pressing this key.</li> <li>- Picks up the temporarily closed Item Track by entering Track # and pressing this key.</li> <li>- Displays the remaining number of blocks of Item Track Memory in the <b>X</b> control key position.</li> <li>- Selects one of Item Tracks at a table which are picked up by using <b>TABLE #</b> key.</li> <li>- Displays an Item Track # in Scroll Display Mode if it has been entered.</li> </ul>
83	ITEM TRANSFER	<b>Item Track System only</b> Transfers items in a transaction or in an Item Track to a new track or a specified Item Track in Scroll Display Mode.
	JPF (Journal Paper Feed)	Advances the journal paper.
39	KP DATA SEND	Sends all PLU data in a transaction to kitchen printers before closing.
38	LOOK UP PLU 1 ~ 40	Enables a list of up to 40 assigned PLUs to be displayed by depression of a single LOOK UP PLU key.
57	MEDIA REFUND	Used if a transaction to be refunded was closed by plural media keys. It is not required to do if the transaction was closed by one media key. The refunded amounts are subtracted from the respective media memory, but they are <b>not</b> memorized in the refund memory.
26	MENU SHIFT 1, 2	Shifts or cancels the PLU menu level. Via menu shift, the keyboard can have three different menus. The menu shift remains for one registration, for one transaction or the menu shift remains until the next shift key is pressed by programming.
66	MESSAGE	Enters an alphanumeric message or digits (up to 20 digits). Entered messages are printed on top of kitchen printer sheet.
60	NET SBTL	Displays the net subtotal amount, not including add-on tax amount but including VAT tax amount. Can be programmed to display and print, or display only by [SF-81.c].

74	NB (New Balance) for Item Track System	<ul style="list-style-type: none"> <li>- Temporarily closes a transaction including an Item Track and saves the amount in New Balance memory.</li> <li>- Used for Item Track Transfer and Track Consolidation in Floating Item Track System.</li> <li>- Under Clerk Interrupt System, this key stores a clerk's transaction to Clerk Interrupt Memory.</li> </ul>
64	NO SALE	Used for opening the drawer for no sale operations.
64	OFF COMPULSORY	Releases compulsory conditions of slip validation, number of people input, message input, etc.
	PAGE UP / DOWN	<ul style="list-style-type: none"> <li>- Moves a cursor by a page on the display.</li> <li>- Enters into Scroll Display Mode during a transaction and scrolls up or down the previously registered items on the display.</li> <li>- Used to adjust the contrast of display when WARN MESSAGE# 03 is displayed (clerk signed off condition) more dynamically than by SCROLL UP/DOWN keys.</li> </ul>
63	P / O (Paid Out)	Records an amount of money withdrawn from the cash drawer when no customer transaction has taken place.
50	% 1 ~ % 3	Enters a percentage rate for mark-up or mark-down of an item or the subtotal amount depending on the operation. Manual % rate is prohibited by programming.
65	PERSON	<ul style="list-style-type: none"> <li>- Enters a number of people (at a table). It is possible to override this number.</li> <li>- Displays a number of people in Scroll Display Mode if it has been entered.</li> </ul>
22	HARD PLU 1 ~ 165	<ul style="list-style-type: none"> <li>- Registers a PLU with the preset price directly.</li> <li>- <b>HARD PLU 1 and 2</b> keys are used to complete the cash declaration which is used to confirm the cash in drawer 1 and 2 at the end of the day.</li> </ul>
29	PLU MODIFIER 1 ~ 3	<ul style="list-style-type: none"> <li>- Modifies the PLU code or cancels the modifier. Using PLU modifiers, one PLU can be changed to three other PLUs. This can be used for three sizes, kinds, etc.</li> <li>- The operation is permitted or prohibited by each PLU programming [PF-2.a].</li> <li>- It remains for one registration, for one transaction or the modifier remains until the next modifier key is pressed by [SF-70.a,b].</li> </ul>
22 23	PLU / REPEAT	<ul style="list-style-type: none"> <li>- Used for code-entry PLU registration. Enter PLU code, then press this key.</li> <li>- Repeats registration of the last-registered item.</li> </ul>
94	PB+ / PB- (Previous Balance)	Enters the previous balance manually without using a track. <b>PB+</b> is used when the previous balance is positive (charge). <b>PB-</b> is used when the previous balance is negative (deposit).
43	PRESET TENDER 1 ~ 10	Enters a preprogrammed tendering amount directly by key depression. The tendering amount is memorized in one of the total key (media) memories selected by SP-253.
23	PRICE	Manually overrides the price of a code-entry PLU. This key is not needed to override the price of a hard PLU. Enter a price, press this key, then enter the PLU code and press <b>PLU/REPEAT</b> key.
26	PRICE SHIFT	Shifts or cancels a second PLU price. The price shift remains for one registration, for one transaction or the price shift remains until the next shift key is pressed by [SF-69.e,f].
69	RECALL	Displays the total amount of the last transaction during the current transaction. Recall can be executed only when the last transaction is closed by direct media closing.
110	RECEIPT OFF	Inhibits receipt printing. However, post-receipt may be issued by pressing <b>BUFFER PRINT</b> key.
	RPF (Receipt Paper Feed)	Advances the receipt paper.
63	R / A (Received on Account)	Records an amount of money received into the cash drawer when no customer transaction has taken place.
57	REFUND	Refunds a previously registered item.
32	SCALE	Displays the weight of items. Press this key before scalable PLU key is pressed if necessary.

	SCROLL UP / DOWN	<ul style="list-style-type: none"> <li>- Used to adjust the contrast of display when WARN MESSAGE# 03 is displayed (clerk signed off condition).</li> <li>- Enters into Scroll Display Mode during a transaction and scrolls up or down the previously registered items on the display. (Press <b>ENTER</b> to exit from Scroll Display Mode.)</li> </ul>
77	SLIP OFF	<ul style="list-style-type: none"> <li>- Prints slip contents on the receipt before pressing <b>BUFFER PRINT</b> key or <b>CHECK-OUT BILL</b> keys. Can be used when ECR is programmed to use a slip printer.</li> <li>- Two-time depression cancels the slip off condition.</li> </ul>
	SLIP RELEASE for TP-620	Moves the slip printer's "slip bed" down in the <b>R</b> control key position.
18	STORAGE for Clerk Interrupt System	Stores a clerk's transaction to Clerk Interrupt Memory when Clerk Interrupt System [SF-12.a=1] is used.
60	SBTL (Subtotal)	<ul style="list-style-type: none"> <li>- Displays the subtotal amount, including tax. Can be programmed to display and print, or display only.</li> <li>- When an add-on tax item is registered, this key is used in combination with <b>TAX SHIFT</b> keys to display each taxable subtotal amount.</li> </ul>
80	TABLE #	<p><b>Item Track System</b></p> <ul style="list-style-type: none"> <li>- <b>Automatic Item Track # Method [SF-15.a=0]</b> Table number assignment is available. Track pick-up by table number is available under non-clerk interrupt system [SF-12.a=0]</li> <li>- <b>Manual Item Track # Method [SF-15.a=1]</b> Table number assignment is available under clerk interrupt system [SF-12.a=1] but Track pick-up by table number is not available.</li> <li>- Shows the first Item Track # which has been assigned to the table when this key is pressed after the table # entry. If only one track has been assigned to the table, <b>TABLE #</b> key opens the track.</li> <li>- After the table is picked up, the depression of <b>TABLE #</b> key skips to the next assigned track.</li> <li>- Displays a table # in Scroll Display Mode if it has been entered.</li> </ul> <p><b>Amount Track System</b> Not available to assign table number into Amount Track. Although it can be entered and printed on a receipt under Clerk Interrupt System, the table number is not memorized.</p> <p><b>Clerk Interrupt System [SF-12.a=1]</b> Table number assignment to clerk's transaction is available.</p>
32	TARE	Adjusts the total weight in order to avoid adding the tare weight on the item weight. It is done either by using programmable tare table or by entering tare weight manually.
60	TAX (only for add-on tax)	<ul style="list-style-type: none"> <li>- Calculates the add-on tax and prints and displays the tax inclusive subtotal.</li> <li>- Used, in combination with <b>TAX SHIFT</b> keys, for manually entering an add-on tax amount and for tax exemption.</li> </ul>
60	TAX SHIFT 1 ~ 4	<p><b>VAT item:</b> This key shifts the tax status to the designated tax.</p> <p><b>Add-on tax item:</b></p> <ul style="list-style-type: none"> <li>- Reverses the tax status.</li> <li>- Allows the taxable subtotal amount to be displayed, in combination with <b>SBTL</b> key.</li> <li>- Allows the tax amount to be entered manually, in combination with <b>TAX</b> key.</li> <li>- Allows tax exemption by <b>TAX</b> key, if permitted by programming [SF-23.a~d].</li> </ul>
	TEN-KEYS (0 ~ 9, 00, 000, •)	For entry of numeric values, percentage rates, PLU codes, report number, programming numbers, etc.
100	TICKET OFF	Temporarily cancels the ticket condition for one transaction when this key is pressed at the beginning of a transaction in Ticket System [SF-1.b=1].
16	TIME-IN / -OUT	Used for clerk's Time-in/Time-out operations. By these operations, clerks' labor hours per 99 job numbers are shown on the report (#19).
49	TIP	Enters a tip amount. Amount can be entered as either an amount separate from payment or as change from over-tendering.

43	TTL 1 ~ 24, CASH/TTL 25 (media keys)	<p>Closes transactions with or without a tendered amount.</p> <ul style="list-style-type: none"> <li>- <b>TTL 1 ~ 24</b> keys can be programmed as one of local, foreign, Euro currency media, credit card media or cheque media.</li> <li>- <b>TTL 25</b> key is fixed as a local currency media.</li> <li>- <b>TTL 25</b> key is used for cash declaration, report printing, track transfer and track consolidation in combination with <b>NB</b> or <b>CHARGE</b> key, etc.</li> </ul>
56	T. VOID (transaction void)	<ul style="list-style-type: none"> <li>- Voids all the registrations in a transaction with <b>TTL 25</b> key depression. This is available only before the transaction is closed.</li> <li>- Two-time depression cancels the transaction void.</li> </ul>
44	TRAY SBTL	Prints the total amount of items per customer in a transaction.
67	MEDIA/ITEM (MISC.) VALIDATION	Prints the item validation and the media validation. The slip validation is available if ECR is programmed for use with a slip printer TP-620.
67	TOTAL VALIDATION	Prints the total validation. The slip validation is available if ECR is programmed for use with a slip printer TP-620.
53	VOID	<ul style="list-style-type: none"> <li>- Voids a previously-registered item within the same transaction. If permitted by programming, a negative void operation can be done.</li> <li>- Selects an item to be voided in Scroll Display Mode.</li> </ul>
25 99	X1	<ul style="list-style-type: none"> <li>- Used for a square entry (measurement calculation).</li> <li>- Used for a multiple ticket issue.</li> </ul>
43 25 91	X2 / FOR / TIME	<ul style="list-style-type: none"> <li>- Multiplies a PLU or a <b>PRESET TENDER</b> key that has a preset tendering amount.</li> <li>- Used for a split pricing operation.</li> <li>- Divides Item Track's balance by the number entered.</li> <li>- Makes a new track in Floating Item / Amount Track System.</li> <li>- Displays the date and time.</li> </ul>

## VI. OPERATION SEQUENCES

---

### 1. Clerk Time-in / Time-out (optional memory board required)

By Time-in and Time-out operation, clerk's attendance information is memorized in the ECR. The clerk's labor hours per 99 job numbers are calculated on the ECR by the clerk's time-out operation and they are printed on the Time & Attendance report (#19), so that the owner may not have to calculate each clerk's labor hours per job.

These operations must be done on the same ECR and do not let clerks sign on or sign off so that all clerks are required to perform Sign-on / Sign-off operation respectively. (See next page.)

#### < Time-In >

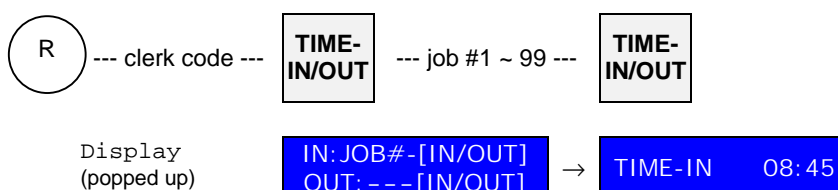

#### Receipt

TIME-IN	1#	time-in message, clerk code
CLERK NAME	00001	clerk name
JUL03/2003 08:45	J01	<b>time-in date, time, job code</b>
-----/-----	---:---	time-out date, time, labor hour
#001-000001	08:45R	machine #, consecutive number, 2-digit clerk symbol [SF-11.a], time, control key position

#### < Time-Out >

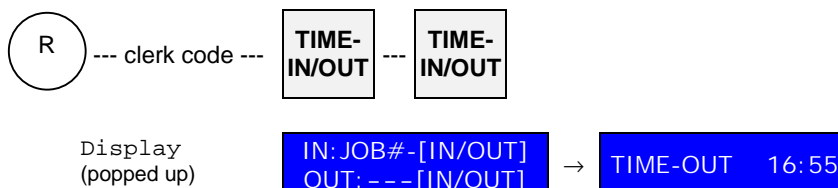

#### Receipt

TIME-OUT	1#	time-out message, clerk code
CLERK NAME	00001	clerk name
JUL03/2003 08:45	J01	time-in date, time, job code
..... 16:55	08:10	<b>time-out date, time, labor hour</b>
#001-000051	16:55R	(date is not printed if it is the same day)

## 2. Clerk Sign-on / Sign-off

Each clerk must sign on before registration to ensure that sales data in his/her clerk memory is recorded correctly. Even if a clerk does not sign off, when the next clerk signs on, he/she will be automatically signed off.

When the optional Clerk iButton System was selected, other methods (clerk code, Hard clerk key, clerk card) can not be used.

### < Sign-On >

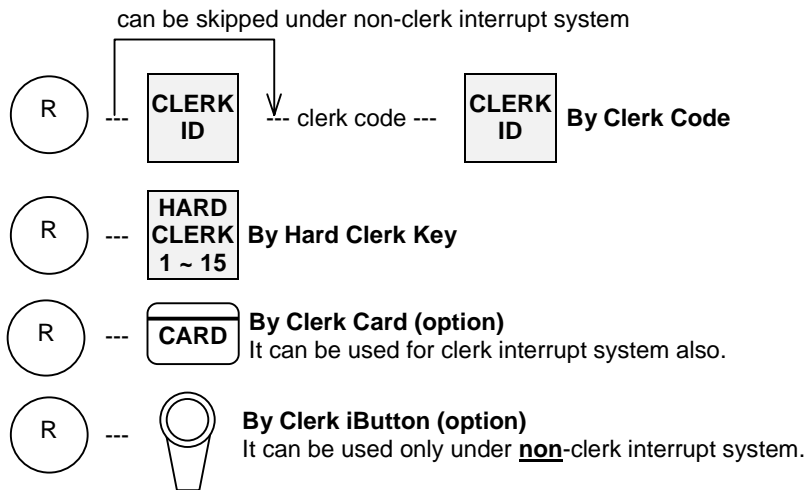

### < Sign-Off >

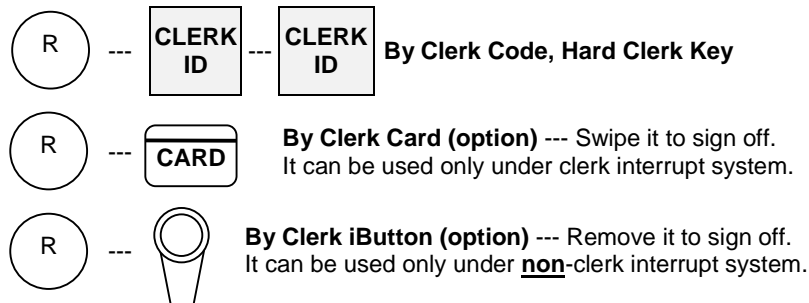

### 3. Clerk Interrupt System

When the clerk interrupt system is selected by the programming [SF-12.a], even if a clerk is in a middle of registrations, another clerk can sign on to operate the ECR.

The incomplete transaction of former clerk can be stored in his/her clerk's memory and the clerk is automatically signed off. The stored transaction can be recalled by his/her clerk sign-on operation and he/she can continue the registrations.

There are the following cases that a clerk's transaction is automatically stored in his/her memory:

- the same **Hard Clerk** key, **Clerk Code**, **Clerk Card** are entered (clerk iButton can not be used)
- the sign-off operation is performed
- other clerk interrupts
- **STORAGE** key or **NB** (New Balance) key is pressed
- by the automatic storage timer

Notes:

- The receipt will **not** be printed until the clerk's transaction is closed finally by a media (total) key.
- Instead of the receipt issue, Item Confirmation Receipt without tax data is issued to check a temporarily stored transaction.

#### < Item Confirmation >

This is available only when clerk's transaction is stored and if permitted by programming [SF-12.d].

To issue the item confirmation, perform the operation below after the transaction is stored.

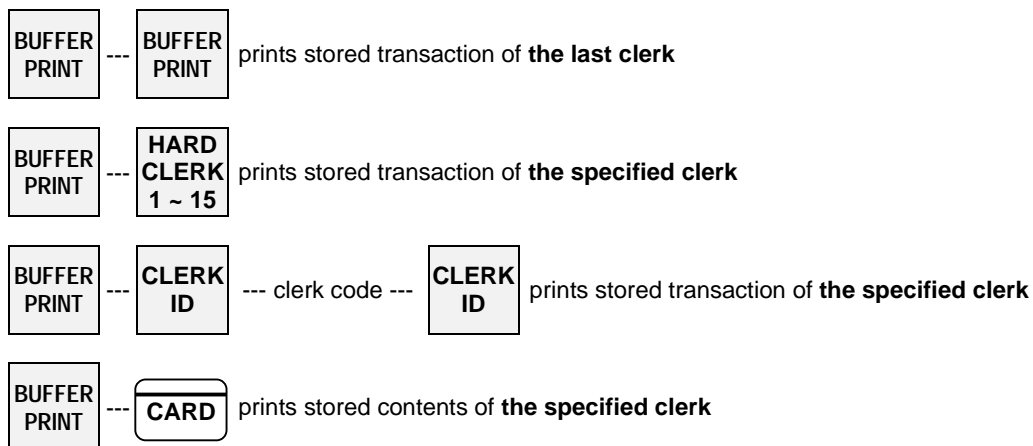

Notes:

- Item Confirmation will not include tax data.
- If an item confirmation is attempted for a clerk with zero balance, press **CL** key in order to reactivate the keyboard.
- If the ECR is programmed for the slip printer, Item Confirmation is printed on the slip printer. If it is required on a receipt, press **SLIP OFF** key first, then perform Item Confirmation operation.

Clerk Interrupt System		
KEY ENTRY	DISPLAY (on the top)	JOURNAL
HARD CLERK 1	CLERK NAME 00001	< 0 1 >
BEER		BEER 3.00
(clerk 2 interrupts clerk 1)		< 0 1 >
HARD CLERK 2	CLERK NAME 00002	< 0 2 >
SODA		SODA 1.00
		< 0 2 >
-- timer --	WARN MESSAGE #03	stored automatically after the time limit expires [SF-13.d-h]
Item confirmation of the specified clerk		CONFIRMATION RECEIPT (Clerk 2's stored item)
BUFFER PRINT 1	CLERK #	< 0 2 >
HARD CLERK 2		SODA 1.00
		-----
		SUBTL BILL 1.00
		#001- 15:36R
		CLERK NAME 00002
		key/symbol #69 consecutive # is not printed
		FINAL RECEIPT (Clerk 1 closes by CASH)
HARD CLERK 1		< 0 1 >
CASH		BEER 3.00
		CASH 3.00
		#001-000004 15:40R
		CLERK NAME 00001
		consecutive # is printed

### Regarding Clerk Sign Off:

Even though the clerk's transaction is finally closed by a media (total) key, the clerk still remains signed on if "Clerk entry compulsory before each transaction [SF-12.g]" is not selected. Clerk signs off automatically if [SF-12.g] is selected and WARN MESSAGE #03 is displayed on the top line.

### < Table Number Assignment >

4-digit table number assignment is available. However, a transaction pick-up by table number is not allowed.

KEY ENTRY	DISPLAY (on the top)	RECEIPT
HARD CLERK 1		< 0 1 > *...5*
5 TABLE #	* 5*	BEER 3.00
BEER		CASH 3.00
CASH		#001-000005 15:40R
		CLERK NAME 00001
		< 0 1 > * . . . 5 *
		table # printed in double-width by [SF-7.c] (not for KP)
		KITCHEN PRINTER
		ECR NAME --> K.NAME 01
		< 0 1 > *...5* CLERK NAME 00001
		1 BEER
		JUL03/2003#001-000005 15:40
		-----

### < Note for Kitchen Printer Items >

Depending on programming [SF-81.b], items are transmitted to a kitchen printer only when a clerk's transaction is finally closed by a media (total) key or every time when it is interrupted (closed temporarily).

## 4. Floating Clerk Interrupt

Almost all operations are same as the normal clerk interrupt system. The only difference is the clerk data is floating among ECRs in the IRC system. In order to use this system, IRC status check must have been made with each ECR.

The following describes the key sequences and memory conditions on the master which picks up the clerk's temporarily closed transaction data and the slave ECRs.

### < Clerk's Transaction Pick Up >

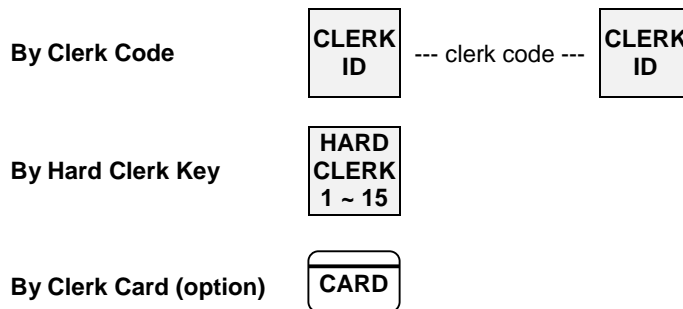

If the clerk's transaction data does not exist on the master, the master searches the slaves and collects the data from it. The collected data is deleted from the slave.

### < Item Confirmation >

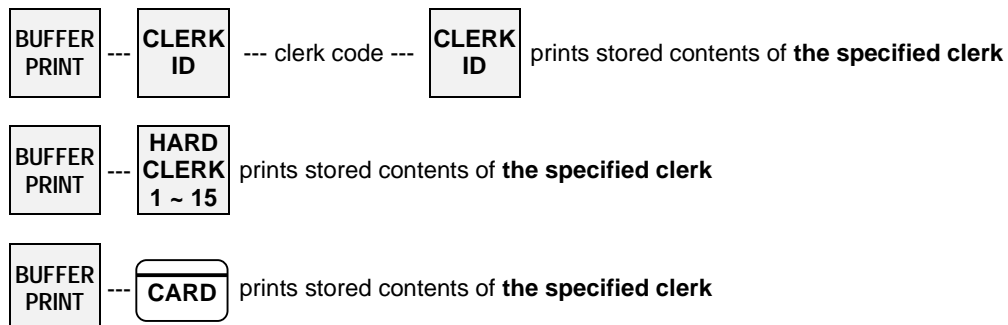

If the clerk's transaction data does not exist on the master, the master searches the slaves and collects the data from them, then prints the item confirmation. The collected data is deleted from the slave.

**< Notes for Communication Error >**

**If a communication error occurs**, one of "-- IRC BUSY --, ECR#-xxx ERROR or ECR#-xxx BUSY" (xxx = ECR machine number) is displayed, then;

- retry the communication by pressing **CASH/TTL 25** key, or
- cancel the communication by pressing **CL** key, then check the slave ECRs causing the communication error.

When **CL** key is pressed, depending on the cases, the master displays **REQ . Z70-xxx** or **REQ . X70-xxx** with sequential clerk number (not clerk code) and prints the message on the journal.

**When REQ . Z70-xxx is displayed,**

(This is displayed when the master collects the clerk's data from the slave, but the slave has not deleted it yet.)

1. Press **CL** key again to clear the error condition.
2. Then perform the clerk code entry again to continue the operation.
3. After the operation is completed, take **Z-70 individual clerk balance report on the ECR machine number xxx** to delete the clerk's data on that ECR so that the master and slave may not have the same clerk's data.

**When REQ . X70-xxx is displayed,**

(This is displayed when the master collects the clerk's data from the slave and the slave deletes it but the confirmation of such deletion has not been sent to the master yet.)

1. Press **CL** key again to clear the error condition.
2. Then perform the clerk code entry again to continue the operation.
3. After the operation is completed, take **X-70 individual clerk balance report on the ECR machine number xxx** to ensure that the clerk's data has been deleted from the slave.

## 5. PLU

There are three kinds of PLUs.

1. **Bar Coded PLUs** can be programmed and registered by a scanner.

Procedure: Scan the bar code labeled on each item while the control key is at the R position.

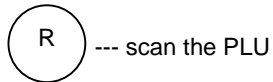

2. **HARD PLU keys** can be allocated to the keyboard.

Total 90 for stroke keyboard, 152 for flat keyboard out of 165 Hard PLU keys can be allocated.

Procedure: Press one of **H. PLU** keys while the control key is at the R position.

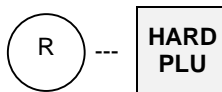

3. **Code Entry PLUs** are any PLUs which are not allocated to a key on the keyboard.

Procedure: Enter the code for the PLU using **Ten-Keys** and then press **PLU** key while the control key is at the R position.

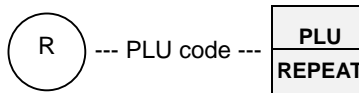

<p>KEY ENTRY</p> <p>HARD CLERK 1</p> <p>HARD PLU 1 (ORANGE)</p> <p>scan bar coded PLU (COFFEE 10 PACKS)</p>	<p>RECEIPT</p> <table border="1" style="width: 100%; border-collapse: collapse;"> <tr> <td>P-----1#</td> <td></td> </tr> <tr> <td>ORANGE</td> <td style="text-align: right;">1.00</td> </tr> <tr> <td>P--490220103956#</td> <td></td> </tr> <tr> <td>COFFEE 10 PACKS</td> <td style="text-align: right;">5.00</td> </tr> </table>	P-----1#		ORANGE	1.00	P--490220103956#		COFFEE 10 PACKS	5.00	<p>PLU code printed (not displayed) by [SF-68.h=1]</p>
P-----1#										
ORANGE	1.00									
P--490220103956#										
COFFEE 10 PACKS	5.00									

Following are some samples of PLU operation sequences.

**a) Manual Price Entry**

A preset price for a PLU can be over-ridden with a manually entered price. When [SF-32.h] is selected, you must turn the control key to the **X position** after the manual price is entered.

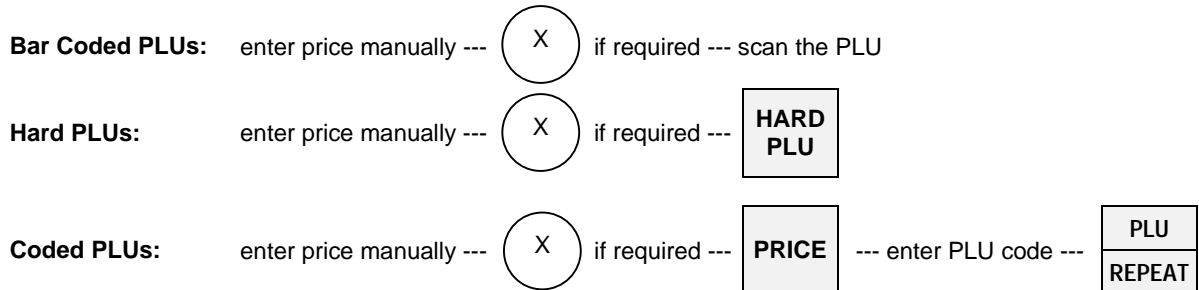

**b) Repetition**

The last registered PLU, including multiplication, can be repeated. Simply press **REPEAT** key the number of times required immediately after a PLU entry.

KEY ENTRY	RECEIPT
CARROT CAKE	CARROT CAKE 4.00
PLU/REPEAT	CARROT CAKE 4.00

### c) Multiplication

According to the flag selections [SF-67.f] and [PF-5.f] (see below), a PLU can be multiplied up to 999.999 or 9999 quantities using **Ten-Keys** and **X2** key. Maximum sales quantity and stock of PLU is 79999.999. So check PLU reports (40/41/42) and take Z reports not to overflow them when 9999 multiplication is selected.

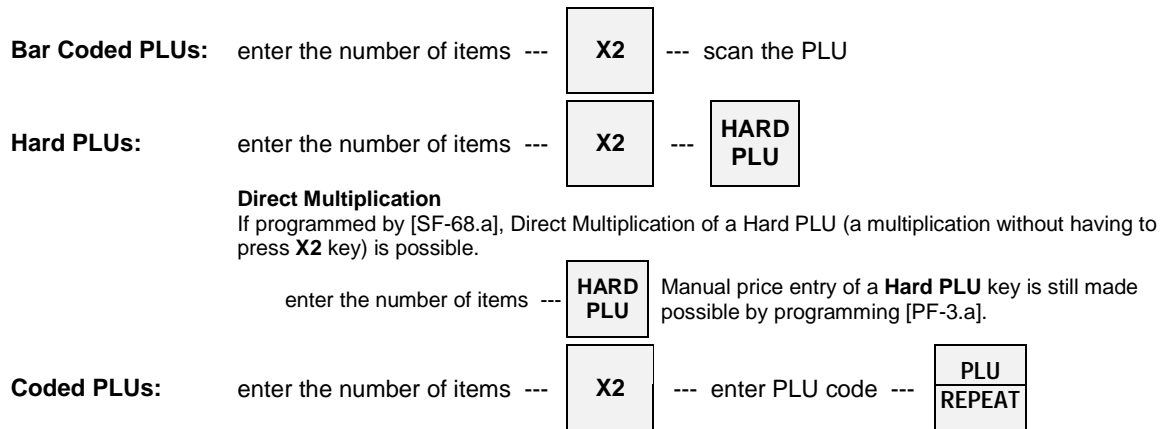

KEY ENTRY	RECEIPT		
2 [X2] BEER	<table border="1"> <tr> <td>2 X 2.50 BEER</td> <td>5.00</td> </tr> </table>	2 X 2.50 BEER	5.00
2 X 2.50 BEER	5.00		
Note for Display: - Entered number is displayed on the top by [SF-119.d=0] or popped up by [SF-119.d=1]. - Quantity displayed by [SF-119.e=0]. - Enlarged quantity displayed [SF-119.f=1] - Regardless of "quantity displayed" [SF-119.e] setting, enlarged PLU quantity is displayed by [SF-119.f.g=11].			

#### System function flag

SF-67	1/0	bit	1	0
		f	Quantity for multiplication 9999 [PF-5.f=1] or 999.999 [PF-5.f=0] When scale is connected, this function is available for standard scale type only [SF-25.b,c,d=000].	999.999 only

#### PLU function flag

PF-5	1/0	bit	1	0
		f	Quantity for multiplication 9999 Registrations of split pricing, square entry and multiplication with decimal for this PLU are prohibited. When scale is connected, this function is available only for standard scale type [SF-25.b,c,d=000].	999.999

### d) Split Pricing

Split pricing can be done by using **X2** key as shown in the sequence below.

enter the loose quantity --- **X2** --- enter the lot quantity --- **X2**

Two bottles of beer are sold from a six-pack.	
KEY ENTRY	RECEIPT
2 [X2] 6 [X2] BEER 6 btls	2 / 6 X 6.60 BEER <6 btls> 2.20
loose quantity / lot quantity X unit price	
Note for Display:	
- Entered number is displayed on the top by [SF-119.d=0] or popped up by [SF-119.d=1]. The calculated split quantity, "0.333" in this sample, is displayed only when [SF-119.d=1] is selected.	
- Quantity, "2 / 6 X" in this sample, displayed by [SF-119.e=0].	
- Enlarged quantity displayed [SF-119.f=1]	
- Regardless of "quantity displayed" [SF-119.e] setting, enlarged PLU quantity is displayed by [SF-119.f,g=11].	

### e) Square Entry (Measurement Calculation)

Square entry can be done by using **X2** key and **X1** key as shown in the sequence below.

enter the ratio to standard width --- **X2** --- enter the ratio to standard length --- **X1**

WRAPPING: 1.00 for width 1 meter and length 1 meter When the WRAPPING with a measurement of 1.5 m (W) x 1 m (L) is sold	
KEY ENTRY	RECEIPT
1.5 [X2] 1 [X1] WRAPPING	1.5 X 1 X 1.00 WRAPPING 1.50
1.5: ratio to standard width, 1: ratio to standard length	
After pressing <b>X2</b> key, a number with a decimal can not be entered for the ratio to standard length.	
Note for Display:	
- Entered number is displayed on the top by [SF-119.d=0] or popped up by [SF-119.d=1]. The calculated split quantity, "1.500" in this sample, is displayed only when [SF-119.d=1] is selected.	
- Quantity, "1.5 X 1 X" in this sample, displayed by [SF-119.e=0].	
- Enlarged quantity displayed [SF-119.f=1]	
- Regardless of "quantity displayed" [SF-119.e] setting, enlarged PLU quantity is displayed by [SF-119.f,g=11].	

### f) Price Shift

Every PLU can have two prices. One is used for the normal preset price and the other is used for happy hour price, service price, etc. (When [SF-69.c] is selected, you must turn the control key to the **X position** before PRICE SHIFT key is pressed.)

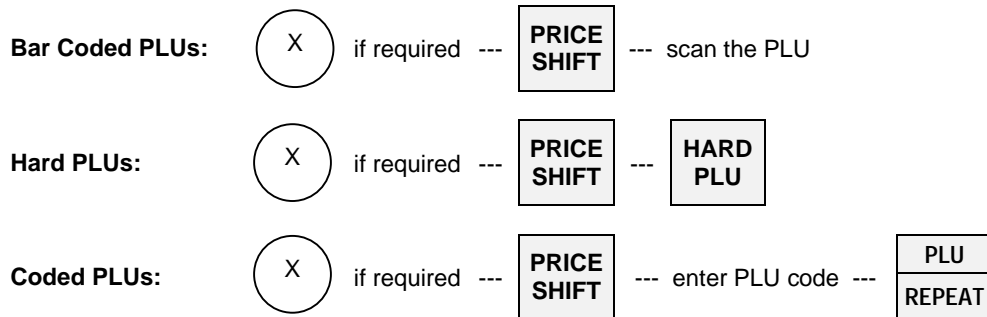

Std Price (key/symbol #85) displayed on the top is changed to 2nd Price (key/symbol #86) when **PRICE SHIFT** key is pressed.

Note: The price shift remains for one registration, for one transaction or until pressing **PRICE SHIFT** key depending on programming [SF-69.e,f].

### g) Menu Shift

The hard PLU key layout can be changed to **three** different preprogrammed layouts using two menu shift keys by PGM-111 Menu Layout. Pressing the same menu shift key cancels the menu and pressing the other menu shift key changes the menu. (When [SF-69.d] is selected, you must turn the control key to the **X position** before MENU SHIFT key is pressed.)



Std Menu (key/symbol #82) is displayed on the top.

Menu 2 (key/symbol #83) is displayed on the top when MENU SHIFT 1 key is pressed.

Menu 3 (key/symbol #84) is displayed on the top when MENU SHIFT 2 key is pressed.

Note: The menu shift remains for one registration, for one transaction or until the next shift key is pressed, depending on programming [SF-69.g,h].

## ***h) Link PLU***

Every PLU can be linked to one PLU. Each link PLU can have its own link PLU as well. This is limited to nine link PLUs. In other words, max. ten PLUs can be automatically registered by simply registering one PLU.

When a PLU with a link PLU is registered, the link PLU is also registered automatically and the total amount of the PLU and link PLU will be displayed.

Link PLU has a symbol "◇" on the receipt. If the link PLU does not need to be printed, then, "PLU not printed" can be programmed by [PF-1.a] for the PLU (but always displayed). Also, a link PLU itself can be registered. This function is useful for set menu or bottle return operations, etc.

<b>Set Menu:</b> SODA <M> is linked to HOT DOG SET. POTATO is linked to SODA <M>.									
KEY ENTRY	RECEIPT								
HOT DOG SET	<table border="1"> <tr> <td>HOT DOG SET</td> <td>5.00</td> </tr> <tr> <td>◇SODA&lt;M&gt;</td> <td>1.00</td> </tr> <tr> <td>◇POTATO</td> <td>1.00</td> </tr> <tr> <td>CASH</td> <td>7.00</td> </tr> </table>	HOT DOG SET	5.00	◇SODA<M>	1.00	◇POTATO	1.00	CASH	7.00
HOT DOG SET	5.00								
◇SODA<M>	1.00								
◇POTATO	1.00								
CASH	7.00								

<b>Bottle Link:</b> Bottle is linked to SODA <bt1>							
KEY ENTRY	RECEIPT						
SODA <bt1>	<table border="1"> <tr> <td>SODA &lt;bt1&gt;</td> <td>0.70</td> </tr> <tr> <td>◇bottle</td> <td>0.10</td> </tr> <tr> <td>CASH</td> <td>0.80</td> </tr> </table>	SODA <bt1>	0.70	◇bottle	0.10	CASH	0.80
SODA <bt1>	0.70						
◇bottle	0.10						
CASH	0.80						
For bottle return operations, the link PLU itself should be refunded by REFUND key.							

Operations for PLU (main PLU) and link PLU are available as follows:

<b>Available on both PLUs</b>	price shift split pricing void refund last item correction mark-up / mark-down % on subtotal adjustment (automatic % on specific items) amount plus / discount on subtotal
<b>Available on main PLUs only</b>	manual price tax shift cooking message mark-up / mark-down % on item amount plus / discount on item ticket item (Ticket setting for the link PLU belongs to the main PLU.)
<b>Available on both PLUs (depending on programming)</b>	single item programmed supplementary message (automatic) kitchen printer transfer (If a different kitchen printer is programmed by main PLU and link PLU, both PLUs will be transmitted to each programmed kitchen printer.)

**i) Simple Condiment PLU**

Simple Condiment PLU (S.C. PLU) programmed by [PF-5.b] is printed with condiment mark "□". It can be entered only with a main PLU.

Simple Condiment PLU entry is compulsory after the registration of Main PLU on which [PF-5.c] is selected.

SALAD has been set to Simple Condiment PLU.	
KEY ENTRY	RECEIPT
STEAK	STEAK 12.00
SALAD	□SALAD 2.00
	STEAK 12.00
	□SALAD
	0 price permitted [PF-3.g] is programmed.

Operations on Simple Condiment PLU are available as follows:

<b>Available</b>	manual price price shift split pricing last item correction mark-up / mark-down % on item, on subtotal amount plus / discount on item, on subtotal adjustment (automatic % on specific items) single item tax shift programmed supplementary message (automatic) kitchen printer transfer --- printed in double-height character (see Note below)
<b>Not Available</b>	void (see Note below) refund (see Note below) cooking message ticket item (see Note below)

**Note for Kitchen Printer Transfer**

If a different kitchen printer is programmed by main PLU and S.C. PLU, both PLUs are transmitted to each programmed kitchen printer.

**Note for Void**

S.C. PLU is not voided at the same time when a main PLU is voided. First, void the main PLU, then void the S.C. PLU. However, S.C. PLU is voided when a main PLU is voided by Scroll Void function (page 53).

**Note for Refund**

S.C. PLU is not refunded at the same time when a main PLU is refunded. First, refund the main PLU, then refund the S.C. PLU. Refund of only the S.C. PLU is not available.

**Note for Ticket**

In the ticket system [SF-1.b], ticket setting of S.C. PLU belongs to the main PLU. S.C. PLU is printed on the same ticket of the main PLU.

### j) PLU Modifier

Using three modifier keys, one PLU can be changed to three different PLUs. Each modifier key is given a 3-digit modifier value (left one digit shows value, right two digits show number of digit).

For example,     modifier value 1 is set at 105,  
                       modifier value 2 is set at 205,  
                       modifier value 3 is set at 305,

Then,   **MODIFY 1** key places a fifth digit with a value of '1' to the PLU code.  
           PLU code 1001 is modified to PLU code 11001.  
           **MODIFY 2** key places a fifth digit with a value of '2' to the PLU code.  
           PLU code 1001 is modified to PLU code 21001.  
           **MODIFY 3** key places a fifth digit with a value of '3' to the PLU code.  
           PLU code 1001 is modified to PLU code 31001.

(When [SF-69.b] is selected, you must turn the control key to the **X position** before PLU MODIFIER key is pressed.)

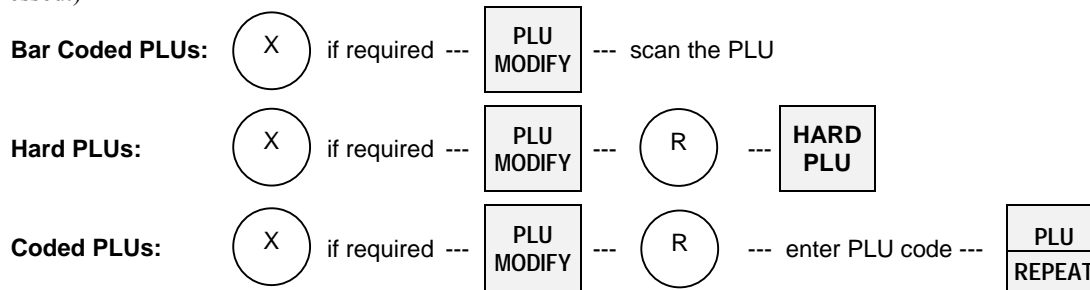

The following PLU codes are set:	
1001:	SODA <S> 0.60
11001:	SODA <M> 0.95
21001:	SODA <L> 1.25
31001:	SODA <LL> 1.50
KEY ENTRY	RECEIPT
SODA	SODA <S> 0.60
	SODA <M> 0.95
MODIFY 1	SODA <L> 1.25
SODA	SODA <LL> 1.50
MODIFY 2	Modifier 1 message (key/symbol #87) is displayed on the top when MODIFY 1 is pressed.
SODA	Modifier 2 message (key/symbol #88) is displayed on the top when MODIFY 2 is pressed.
MODIFY 3	Modifier 3 message (key/symbol #89) is displayed on the top when MODIFY 3 is pressed.
SODA	

Notes:

- To exit from the PLU modifier mode, press the same modifier key again.
- To change the value, press an other modifier key.
- Depending on programming [SF-70.a,b], this modifier value remains for one registration, for one transaction or until the next **PLU MODIFY** key depression.

### k) Single Item

A PLU that has been programmed as a single item automatically closes the transaction by a programmed total key [MF-4.b]. This function is especially useful for the bar since simply registering the single item PLU close the transaction automatically.

There are two types of single item transactions as follows:

**Single-item 1:** This can be used as normal registration with other non-single items and will not automatically close the transaction.

enter the **non-single item** --- enter the **single-item 1** --- can be continued ---

**Single-item 2:** This can be used with non-single items but will automatically close the transaction.

enter the **non-single item** --- enter the **single-item 2** --- closed automatically

Regarding the four examples shown below, examples (1) and (2) show the transaction is closed the same way since only one single item is registered. In example (3), upon registering BEER/single-item 1 following the entry of SANDWICH/non-single item does not close the transaction automatically. In example (4), upon registering MARTINI/single-item 2 following the entry of SANDWICH/non-single item, the transaction is closed automatically.

Single-item 1 = BEER [PF-1.h] -- The transaction is not closed automatically following entry of non-single item.			
Single-item 2 = MARTINI [PF-1.g] -- The transaction is closed automatically following entry of non-single item.			
Non-single item = SANDWICH			
<b>KEY ENTRY</b>	<b>RECEIPT</b>	<b>KEY ENTRY</b>	<b>RECEIPT</b>
(1) BEER	BEER 2.50 CASH 2.50	(2) MARTINI	MARTINI 4.50 CASH 4.50
	Closed automatically		Closed automatically
(3) SANDWICH BEER	SANDWICH 3.00 BEER 2.50	(4) SANDWICH MARTINI	SANDWICH 3.00 MARTINI 4.50 CASH 7.50
	Not closed		Closed automatically

Single item combination for a PLU with link PLU

Programmed as	Transaction will be
Main PLU: single-item 1 or 2 Link PLU: non-single item or single-item 1 or 2	Only the main PLU is registered and closed automatically. The link PLU is not registered.
Main PLU: non-single item Link PLU: single-item 1 or 2	Both PLUs are registered and not closed if link PLU is single-item 1. If link PLU is single-item 2, it is closed automatically.

If a PLU and link PLU which are programmed as single items are entered with other non-single items, the transaction is either closed or not closed depending on the selecting of single-item 1 (can be continued) or single-item 2 (closed automatically).

## 1) Cooking Message & PLU Supplementary Message

### < Cooking Message >

A PLU can have one cooking message that is entered by using **COOKING MESSAGE** key. The cooking message can be either preprogrammed (one of 50 messages) or manually entered. The cooking message is printed under the PLU line on the receipt. However, it is never printed on post-receipt (receipt printed by BUFFER PRINT) and bill.

#### Preprogrammed cooking message:

- Press one of **HARD COOKING MESSAGE 1 ~ 5** keys and then enter a PLU.
- Preprogrammed cooking message:  
Enter a number (called the "Supplementary message number") using numeric keys from 1 to 50 and press **COOKING MESSAGE** key, then enter a PLU.

Preprogrammed cooking message 1 ~ 50: HAMBURGER with bacon (cooking message 7) is sold		
KEY ENTRY	DISPLAY (popped up)	RECEIPT
7	with bacon	HAMBURGER 6.00
COOKING MESSAGE		with bacon
HAMBURGER		

#### To manually enter a cooking message,

- Press **COOKING MESSAGE** key first.
- Enter any alphanumeric message (up to 20 characters).
- Press **ENTER** key.
- Enter a PLU.

Manual entry: Rare STEAK is sold (cooking message "RARE" is manually entered)		
KEY ENTRY	DISPLAY	RECEIPT
COOKING MESSAGE		STEAK 15.00
RARE	<RARE > (on the bottom)	RARE
[ENTER]	RARE (on the top)	
STEAK		

**If a wrong cooking message is entered**, enter another cooking message or press **CR** key before a PLU entry. If REPEAT or MULTIPLICATION operation is performed on a PLU, the PLU with cooking message is also repeated or multiplied.

**< PLU Supplementary Message >**

The supplementary message is the same as the cooking message (the same preprogrammed 1 ~ 50 messages are used) except that it is programmed to be automatically printed when the PLU which is programmed to link to one of the 50 supplementary messages is entered.

The supplementary message is printed above the PLU line but it is not displayed.

<b>HAMBURGER (linked to the supplementary message number 7) is sold</b>		
KEY ENTRY	RECEIPT	
HAMBURGER	HAMBURGER with bacon	6.00
		PLU supplementary message (not displayed)

**m) Sales by Weight**

ECR allows faster sales by weight when a scalable item is sold. Weight unit "kg" or "lb" is selectable and ECR handles scale types such as "standard", "USA/Canada/Quebec", "Australia", "EC" and "France". The print format is different depending on the scale type. Refer to < Print Format > on [page 36](#).

Program options

- scale type [SF-25.b,c,d]
- scale print format for USA scale type [SF-25.f,g]
- weight unit kg or lb [SF-25.e]

**< Using Scale >**

PLUs programmed as scalable PLUs are registered via scale.

- Place the item on the scale.
- Enter the scalable PLU [PF-6.a].

The amount is calculated automatically by weight and unit price, and then displayed and printed on the receipt. It is possible to display the weight also if necessary, by pressing **SCALE** key after the item was placed on the scale.

Warning message #97 "Scale communication error/weight error" is displayed if the item weight on the scale exceeds the limit weight of the scale or the item weight is zero when **SCALE** key is pressed. Reduce the item on the scale or put the item if the weight display is zero to continue the operation.

<b>BEEF unit price 10.00/kg has been set.</b>		
KEY ENTRY	RECEIPT (Standard Scale Type)	
place item on scale	0.33 kg 10.00 kg	
SCALE (if necessary) -- a	BEEF	3.30
BEEF	CASH	3.30
CASH	QUANTITY	1
		Quantity count always added as 1 [SF-68.d=1] is selected

a: Weight indicated by **SCALE** key is displayed on the front display only. It does not show up on the rear display.

Preset price per "kg or lb" may be over-ridden by a price entered manually.

< Manual Weight Entry >

Weight can be entered manually by **ten-keys** and **X2** key. The price is calculated by entered weight and unit price of scalable PLU. Manual weight entry is prohibited for USA scale type except for **REFUND** operation. If scale is not fitted for USA scale type, manual weight entry is always available.

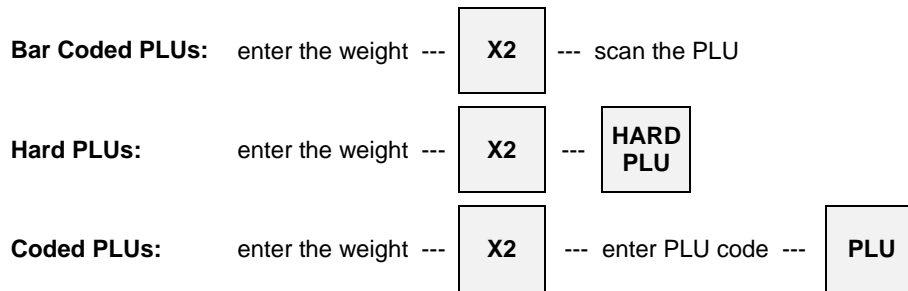

After manual weight entry, the preset price per "kg or lb" may be over-ridden by a price entered manually.

PORK unit price 8.00/kg has been set.

KEY ENTRY	DISPLAY	RECEIPT (Standard Scale Type)
.52 [X2]	Std Menu Std Price 0.52 kg PORK 4.16 CASH 4.16	0.52 kg 8.00 kg PORK 4.16 CASH 4.16 QUANTITY 1
PORK		Quantity count always added as 1 is selected [SF-68.d=1]
CASH		
2nd ~ 9th digits of Supplementary message #50 is printed for manual weight entry message for EC, Australia and France scale type.		
	Std Menu Std Price 0.520 kg PORK *4.16 CASH *4.16	(EC Scale Type) 0.520 kg Manually 8.00/kg PORK *4.16 CASH *4.16 QUANTITY 1
		2nd ~ 9th digits of supplementary message #50 is printed.

< Multiple Pound Price for USA Scale Type Only [SF-25.b,c,d=100] >

When "multiple pound price used" [PF-6.c] is programmed on the scalable PLU, the last digit of the PLU price is regarded as the weight so that the PLU can have a unit price with weight.

When the item is placed on the scale and the PLU is entered, the PLU will have an actual price calculated by the weight.

HAM unit price 1.00/kg has been set. Actually programmed as "1001". (100: price, 1: weight)

KEY ENTRY	RECEIPT
place item on scale	0.370 kg
SCALE (if necessary) -- a	@ 1 kg/1.00
HAM	HAM *0.37
CASH	CASH *0.37
CASH	#001-000004 15:40R
	CLERK NAME 00001

a: Weight indicated by **SCALE** key is displayed on the front display only. It does not show up on the rear display.

< **Refund of Scalable Item** >

• **Standard Scale Type**

When a scalable item is to be refunded, only standard scale type can refund the item by using scale.

place item on the scale --- enter tare weight --- **REFUND** --- scan the PLU or press **Hard PLU** key  
(if required)

place item on the scale --- enter tare weight --- enter PLU code --- **REFUND** --- **PLU**  
(if required)

When a manual weight entry is required, refer to the sequence for other scale types below;

• **Other Scale Types**

Except for standard scale type, weight must be entered manually. Scale can **not** be used for refund operation. Also item placed on the scale can **not** be refunded by France and USA scale types.

**Note for USA Scale Type**

Refund must be done by entering weight manually. Because the weights at purchasing and refund may be different. So REFUND by using scale is prohibited. According to this limitation (manual weight entry prohibited), VOID is always done by using scale.

**Bar Coded PLUs:** enter the weight --- **X2** --- **REFUND** --- scan the PLU

**Hard PLUs:** enter the weight --- **X2** --- **REFUND** --- **HARD PLU**

**Coded PLUs:** enter the weight --- **X2** --- **PRICE** --- enter PLU code --- **REFUND** --- **PLU**

### < Tare Weight Entry >

This function adjusts the total weight to avoid the tare weight being added on the item weight. It is done either by using programmable 99 tare tables or by entering a tare weight manually.

Tare weight should be entered before entering scalable item. Also, when the tare weight is larger than item's weight, warning message #93 will be displayed.

- **Programmable 99 Tare Tables**

Ten-keys and TARE key are used to select pre-programmed tare weight.

Tare weight 45g (0.045kg) has been set to tare table #1. 255g of BEEF is placed on the scale. Then, scale indicates total weight 300g. You can see the weight of item itself by pressing SCALE key.															
KEY ENTRY	DISPLAY (on the top)	RECEIPT (Standard Scale Type)													
place item with vessel on scale 1 TARE SCALE (if necessary) -- a BEEF CASH	<table border="1"> <tr> <td>TR-01</td> <td>0.045 kg</td> </tr> <tr> <td>TARE</td> <td>0.255 kg</td> </tr> </table>	TR-01	0.045 kg	TARE	0.255 kg	<table border="1"> <tr> <td>0.255 kg</td> <td>10.00 kg</td> <td></td> </tr> <tr> <td>BEEF</td> <td></td> <td>2.55</td> </tr> <tr> <td>CASH</td> <td></td> <td>2.55</td> </tr> </table>	0.255 kg	10.00 kg		BEEF		2.55	CASH		2.55
TR-01	0.045 kg														
TARE	0.255 kg														
0.255 kg	10.00 kg														
BEEF		2.55													
CASH		2.55													
a: You can see the weight of item itself excluding the tare weight. It is displayed with 4-digit tare weight entry message (10th~14th digits of Supplementary message #50).															

- **Manual Tare Weight Entry**

Tare weight can be entered manually by **ten-keys**, **X2** and **TARE** keys if it is permitted by PLU function flag [PF-6.e]. The price is calculated by entered weight and unit price of scalable PLU.

Tare weight 0.02 kg (20g) is entered manually and 280g of BEEF is placed on the scale. Then, scale indicates total weight 300g. You can see the weight of item itself by pressing SCALE key.															
KEY ENTRY	DISPLAY (on the top)	RECEIPT (Standard Scale Type)													
place item with vessel on scale .02 [X2] TARE SCALE (if necessary) -- a BEEF CASH	<table border="1"> <tr> <td>TARE</td> <td>0.02 kg</td> </tr> <tr> <td>TARE</td> <td>0.28 kg</td> </tr> </table>	TARE	0.02 kg	TARE	0.28 kg	<table border="1"> <tr> <td>0.28 kg</td> <td>10.00 kg</td> <td></td> </tr> <tr> <td>BEEF</td> <td></td> <td>2.80</td> </tr> <tr> <td>CASH</td> <td></td> <td>2.80</td> </tr> </table>	0.28 kg	10.00 kg		BEEF		2.80	CASH		2.80
TARE	0.02 kg														
TARE	0.28 kg														
0.28 kg	10.00 kg														
BEEF		2.80													
CASH		2.80													
a: You can see the weight of item itself excluding the tare weight . It is displayed with 4-digit tare weight entry message (10th~14th digits of Supplementary message #50).															

< Print Format >

The print format is different depending on the scale types, such as "standard", "USA/Canada/Quebec", "Australia", "EC" and "France".

Following example shows a case when HAM 40g was entered, amount 0.10 was discounted and 5 pcs of BANANAS were entered;

<b>Standard Scale</b>	RECEIPT
place item on scale	0.04 kg 10.00 kg
HAM	HAM 0.40
10 AMOUNT (-)	DSCNT 0.10
5 X2 BANANAS	5 X 2.00 BANANAS 10.00
CASH	CASH 10.30

<b>USA/Canada/ Quebec Scale</b>	RECEIPT: USA
place item on scale	0.040 kg
HAM	@ 10.00/kg
10 AMOUNT (-)	HAM *0.40
5 X2 BANANAS	DSCNT *-0.10
CASH	5.000 X @ 2.00
	BANANAS *10.00
	CASH *10.30

- Scalable item's name is fixed up to 19 characters.
- Programmable currency symbol (1st digit of supplementary message #50) shown by "\*" above and "0" are displayed and printed automatically.
- Minus (-) symbol is displayed and printed between the currency symbol and minus amount.

Basically, the scale specifications for Canada and Quebec are the same as USA scale system. Only a print format of unit price is different depending on [SF-25.f,g] as follows:

USA [SF-25.f,g=00/11]	0.040 kg @ 10.00/kg HAM \$0.40	The local currency symbol is not printed for the unit price.  <b>Before</b> unit price, the local currency symbol programmed by 1st digit of Supplementary Message #50 is printed.  <b>Behind</b> unit price, the local currency symbol programmed by 1st digit of Supplementary Message #50 is printed.
Canada [SF-25.f,g =01]	0.040 kg @ \$10.00/kg HAM \$0.40	
Quebec [SF-25.f,g =10]	0.040 kg @ 10.00\$/kg HAM \$0.40	

<b>Australia Scale</b>	RECEIPT
place item on scale	0.040 kg
HAM	@ 10.00*/kg
10 AMOUNT (-)	HAM *0.40
5 X2 BANANAS	DSCNT *-0.10
CASH	5 pc
	@ 2.00*/ea
	BANANAS *10.00
	CASH *10.30

- Programmable currency symbol shown by "\*" above is printed automatically.  
- Minus (-) symbol is displayed and printed between the currency symbol and minus amount.

<b>EC Scale</b>	RECEIPT
place item on scale	0.040kg *10.00/kg
HAM	HAM *0.40
10 AMOUNT (-)	DSCNT *-0.10
5 X2 BANANAS	5.000 X *2.00
CASH	BANANAS *10.00
	CASH *10.30

- Programmable currency symbol shown by "\*" above is printed automatically.  
- Minus (-) symbol is displayed and printed between the currency symbol and minus amount.

<b>France Scale</b>	RECEIPT
place item on scale	0.040 Kg x 10.00*kg
HAM	HAM *0.40
10 AMOUNT (-)	DSCNT *-0.10
5 X2 BANANAS	5 X *2.00
CASH	BANANAS *10.00
	CASH *10.30

- Programmable currency symbol shown by "\*" above is printed automatically.  
- Minus (-) symbol is displayed and printed before the currency symbol.

< Note for Link PLU >

Scale Weight is effective only in main PLU and quantity of Link PLU is always 1.00.  
Make sure not to set Link PLU as Scalable PLU.

## n) Simple Look Up PLU

### Specifications:

- 40 LOOK UP PLU keys
- Up to 40 PLUs assigned to one LOOK UP PLU key
- PLU list of LOOK UP PLU key is displayed until clear. [LUPF-1.a]
- Menu shift of LOOK UP PLU key is allowed by [LUPF-1.b].  
EX.) LUPLU key can be shifted to other LUPLU key according to the menu shift.
- One LOOK UP PLU key can be linked to one PLU under the condition of [PF-5.e=1].  
EX.) PLU 1 is Sandwich and linked to one LUPLU (Drink).

LOOK UP PLU keys enable a list of up to 40 assigned PLUs to be displayed by depression of a single key. For example, a SALAD key automatically displays a list of all available salads for easy selection.

1. Sign on a clerk.
2. Press the required **LOOK UP PLU** key.
3. A list of PLUs are displayed.



4. Find a PLU from the list by **PAGE UP/DOWN** keys. **SCROLL** keys can be used in one page but can not go to next page.
5. Press **ENTER** to select PLU or enter Numeric key **1 ~ 6** directly.
6. Press **CL** to end under the setting for the list to remain until **CLEAR**.

### Menu Shift of Look Up PLU

Example Settings:

SP-509 Look Up PLU Menu Shift Value	Menu 2 = 03
SP-500 Look Up PLU Function Flag	[LUPF-1.b=0] This Look Up PLU is shifted by MENU SHIFT key

Operation:

1. Sign on a clerk.
2. Press the MENU SHIFT 1 key. Then press the LOOK UP PLU 1 key.

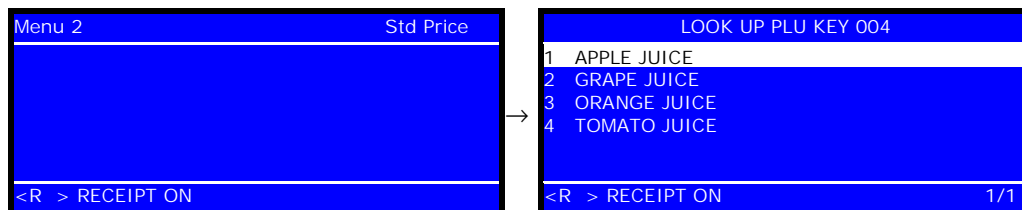

LOOK UP PLU 1 key is shifted to **LOOK UP PLU 4** key by the programmed Menu 2 shift value "03".  
(LUPLU 1+ 03 = LUPLU 4 key)

## 6. Kitchen Printer

The ECR sends PLUs that have been programmed to be printed at specific kitchen printers after the transaction is closed by a media (total) key or by pressing **KP DATA SEND** key before closing. In the clerk interrupt system, when a clerk's transaction is interrupted, the registered items are transmitted to the kitchen printer when [SF-81.b] is selected.

Food: go to the kitchen (KP 1) Drinks: go to the bar (KP 2) SALAD: simple condiment PLU ROAST BEEF has a preprogrammed supplementary message "french fries" and one link PLU "SOUP".																											
KEY ENTRY BEER 1 COOKING MESSAGE CHICKEN SALAD ROAST BEEF BEER BEER CASH	<table border="1"> <thead> <tr> <th colspan="2">RECEIPT</th> </tr> </thead> <tbody> <tr> <td>BEER</td> <td>2.50</td> </tr> <tr> <td>CHICKEN</td> <td>9.00</td> </tr> <tr> <td>    mild sauce</td> <td></td> </tr> <tr> <td><input type="checkbox"/> SALAD</td> <td>3.00</td> </tr> <tr> <td>    french fries</td> <td></td> </tr> <tr> <td>ROAST BEEF</td> <td>14.00</td> </tr> <tr> <td>◇SOUP</td> <td>1.00</td> </tr> <tr> <td>BEER</td> <td>2.50</td> </tr> <tr> <td>CASH</td> <td>32.00</td> </tr> <tr> <td>    QUANTITY</td> <td>6</td> </tr> <tr> <td>#001-000050</td> <td>10:11R</td> </tr> <tr> <td>CLERK NAME</td> <td>00001</td> </tr> </tbody> </table>	RECEIPT		BEER	2.50	CHICKEN	9.00	mild sauce		<input type="checkbox"/> SALAD	3.00	french fries		ROAST BEEF	14.00	◇SOUP	1.00	BEER	2.50	CASH	32.00	QUANTITY	6	#001-000050	10:11R	CLERK NAME	00001
RECEIPT																											
BEER	2.50																										
CHICKEN	9.00																										
mild sauce																											
<input type="checkbox"/> SALAD	3.00																										
french fries																											
ROAST BEEF	14.00																										
◇SOUP	1.00																										
BEER	2.50																										
CASH	32.00																										
QUANTITY	6																										
#001-000050	10:11R																										
CLERK NAME	00001																										
KITCHEN PRINTER 1 AT KITCHEN	KITCHEN PRINTER 2 AT BAR																										
<table border="1"> <tr> <td>           ECR NO.1 --&gt; KITCHEN            CLERK NAME 00001             1 CHICKEN                mild sauce --a             1 SALAD --b                french fries --c             1 ROAST BEEF            1 ◇SOUP             JUL03/2003#001-000050 10:11            -----         </td> </tr> </table>	ECR NO.1 --> KITCHEN CLERK NAME 00001  1 CHICKEN mild sauce --a  1 SALAD --b french fries --c  1 ROAST BEEF 1 ◇SOUP  JUL03/2003#001-000050 10:11 -----	<table border="1"> <tr> <td>           ECR NO.1 --&gt; BAR            CLERK NAME 00001             2 BEER             JUL03/2003#001-000050 10:11            -----         </td> </tr> </table> <p>PLUs are consolidated on KP when "PLU consolidated" [SF-67.h=0] is programmed.</p> <p>a: cooking message          b: simple condiment PLU          c: PLU supplementary message (centered)</p>	ECR NO.1 --> BAR CLERK NAME 00001  2 BEER  JUL03/2003#001-000050 10:11 -----																								
ECR NO.1 --> KITCHEN CLERK NAME 00001  1 CHICKEN mild sauce --a  1 SALAD --b french fries --c  1 ROAST BEEF 1 ◇SOUP  JUL03/2003#001-000050 10:11 -----																											
ECR NO.1 --> BAR CLERK NAME 00001  2 BEER  JUL03/2003#001-000050 10:11 -----																											

**< KP Data Printed on Receipt >**

If programmed so, the printing contents on a kitchen printer are printed on the receipt after the normal receipt printing. In this case, **KP DATA SEND** key can not be used.

Program Option: PLU data for KP 1 ~ 8 printed on receipt [SF-106.a~h=1, SF-107.a~h=0]

**KP data printed on receipt**

<pre>          [5-line logo]            JUL03/2003 ECR NO.1 --&gt; KITCHEN           CLERK NAME 00001            1      X CHICKEN           mild sauce           1      X ☐SALAD french fries           1      X ROAST BEEF           1      X ◇SOUP  #001-000050          10:11R           CLERK NAME 00001</pre>	<p>CHICKEN with cooking message "mild sauce"</p> <p>SALAD is condiment of CHICKEN.</p> <p>"french fries" is pre-programmed supplementary message for ROAST BEEF.</p> <p>SOUP is pre-programmed link PLU to ROAST BEEF.</p>
<pre>          [5-line logo]            JUL03/2003 ECR NO.1 --&gt; BAR           CLERK NAME 00001            2      X BEER  #001-000050          10:11R           CLERK NAME 00001</pre>	

**< Print Contents >**

- Pre-feed lines between cut line and first line are programmed by [SF-4.e,f,g].
- 1st line : the transmitting ECR name and the kitchen printer name are printed in double-width characters.
- 2nd line : the serving clerk's name is printed.
- The quantity and PLU name are printed in double-width characters.
- PLU code is printed by [SF-112.c].

```

P-----5#
2 BEER
    
```

- PLU unit price is printed by [SF-112.d].

```

2 BEER                2.50
    
```

- Link PLU is printed with link PLU symbol "◇" if entered.
- Simple condiment PLU is printed in double-height character without symbol "□" if entered. (Up to 18 digits of condiment PLU name, it is printed in double-height and width character.)
- If programmed by "PLU consolidated" [SF-67.h=0], orders of the same item are combined together. A link PLU and simple condiment PLU however are regarded as separate items from the same main PLUs. Also, they are transmitted to a kitchen printer which has been set for them.
- < Item Track # >, << Amount Track # >> and \* Table # \* are printed in brackets if entered.

```

ECR NO.1 --> KITCHEN
< . . . . . 1 > CLERK NAME 00001
    
```

- Refunded or negative voided items are printed in double-height and width character. (page 57)
- Voided or corrected items in the same transaction are not printed.
- Last line : date, machine number, consecutive number (double-width by [SF-5.a]) and time are printed.

```

JUL03/2003#001-000050 10:11 [SF-5.a=0]
-----
    
```

```

JUL03/2003#001-000050 10:11 [SF-5.a=1]
-----
    
```

- Number of blank lines between cut line and last line are programmed by [SF-5.d,e].

**< KP 1 ~ 8 Data Transfer to KP 1 >**

PLU data transmitted to KP 1 ~ 8 can be printed on KP 1 having the respective kitchen printer's header by [SF-112.a=1, SF-107.h=1].

### < Back-Up Kitchen Printer >

Depending on programming [SF-108 ~ 111], back-up printer can be assigned in case of communication failure, intentional shut down, changing paper rolls, etc. After a transaction is closed and the ECR attempts to send a message to a down kitchen printer, an alarm sounds, and the one of warning messages (81 ~ 88) "kitchen printer 1 ~ 8 error" is displayed.

In the example below, KP 1 at the kitchen shuts down. KP 2 at the bar, programmed as the back-up, prints orders from the kitchen. The warning message #81 (KP 1 error) is displayed on the ECR and all the data sent to the kitchen printer (KP 1) which is down is printed from the back-up kitchen printer (KP 2). The data of the two kitchen printers are printed according to increasing kitchen printer number.

The following example shows data of food, that could not be transmitted to KP 1, are printed out of KP 2. In this situation, KP 2 placed at the bar is used for the back-up printer of KP 1.

KITCHEN PRINTER 2  
AT BAR

```
ECR NO.1 --> KITCHEN
                CLERK NAME 00001

  1 CHICKEN
    mild sauce

  1 SALAD
    french fries

  1 ROAST BEEF
  1 ◇SOUP

                JUL03/2003#001-000051 10:12
-----
ECR NO.1 --> BAR
                CLERK NAME 00001

  2 BEER

                JUL03/2003#001-000051 10:12
```

header of back-up printed in double-height and width character

## 7. Media Closing

Up to 25 different media (total) keys can be used to close a transaction. In addition to these media keys, there are 10 preset tender keys, which have preset tendering amounts by programming, available to close a transaction by one-action.

The following closing methods are available.

**Direct Closing :** Press a media key directly.

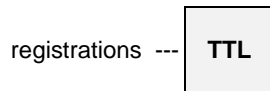

**Tendering Input :** Enter a tendered amount then press a media key.  
Short tendering amount input prohibited for TTL 25 if [MF-1.e] is programmed.

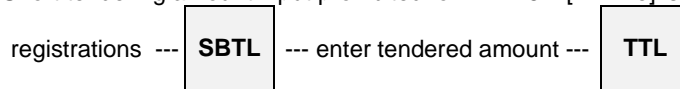

SBTL key depression is required to see the due amount including add-on tax amount.

When entered amount is over the due amount, the change is calculated automatically in cash if "automatic change" [MF-2.e=0] has been programmed.

If "automatic change" has not been programmed by [MF-2.e=1], a designated media [MF-1.e for TTL 1 ~ 24] should be pressed for the change as follows:

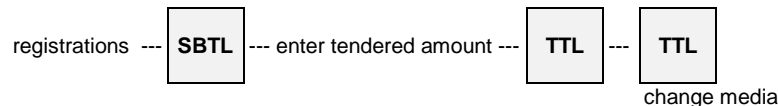

**Preset Tendering :** One-action closing to speed up tendering by use of a preset tender key.  
Preset tendering amount is memorized in the memory of pre-programmed media by SP-253.



**Media Multiplication :** Simply multiplying the preset tender amount will facilitate the closing transaction.  
This function is available only when using one of 10 preset tender keys.

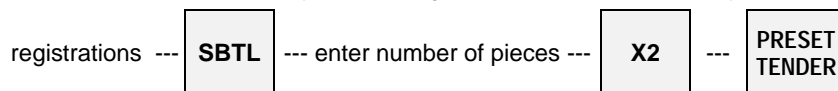

**Automatic Closing by Clerk iButton (option) :**

If programmed by [SF-12.f], when the clerk iButton is removed, the transaction is closed automatically by **CASH/TTL 25** key. For an Item Track operation, it is closed automatically by **NB** (New Balance) key and for an Amount Track operation, it is closed automatically by **CHARGE** key.

**Closing by Credit Card (option) :**

When a media key programmed for **CARD** key is pressed, Warning Message #47 "Swipe Card" is displayed. The transaction is closed by swiping a credit card and the card number is printed below the media key symbol.

Real-time card verification function is also available with a PC via IRC line.

It sends the card data, number and payment amount, which is swiped on ECR to a PC. Then PC sends back the classification in 20-digit message with one of six (6) message types to ECR.

Depending on the received message type, ECR prints and displays the classification message or ECR locks with a buzzer sound.

The following depend on programming:

- automatic change [MF-2.e];
- tendered amount input prohibited or compulsory [MF-1.b,c,d];
- drawer open after media closing [MF-2.a];
- cheque-cashing functions [MF-2.h] (refer to 10. Cheque Cashing / Cheque Printing section);
- cheque printing [SF-64.c] (refer to 10. Cheque Cashing / Cheque Printing section).

## 8. Tray Subtotal

Tray Subtotal Function can be used for a party of customers to show how much each customer has to pay for food and drink. This function is especially useful in a cafeteria where tray is usually used to serve each customer. Press **TRAY SUBTOTAL** key when item registrations are completed per customer. Then, the total amount of items for each customer is printed on the receipt.

Tray Subtotal		RECEIPT	
KEY ENTRY			
Customer A	BEER	BEER	2.50
	1 COOKING MESSAGE	CHICKEN	9.00
	CHICKEN	mild sauce	
	SALAD	<input type="checkbox"/> SALAD	3.00
	TRAY SBTL	TRAY SB TTL	14.50
	(14.50 is popped up)	-----	
		french fries	
		ROAST BEEF	14.00
Customer B	ROAST BEEF	◇ SOUP	1.00
	BEER	BEER	2.50
	TRAY SBTL --- can be skipped	TRAY SB TTL	17.50
	(17.50 is popped up)	-----	
		CASH	32.00
	CASH	QUANTITY	6

Notes:

- When using Tray Subtotal Function, "PLU not consolidated [SF-67.h=1]" must be programmed.
- Add-on tax amount is not included in tray subtotal.

## 9. Foreign Currency / Euro Currency

Any media may be programmed for foreign currency media except for **TTL 25** key which is used for local currency. **Foreign Currency Media** keys can be used the same way as a local currency media, including the R/A, P/O and Cash Declaration operations.

### a) Closing Methods

**Direct Closing :** Press **Foreign Currency Media** key directly, without a tendered amount input.

**Tendering Input :** Before a foreign currency tendering amount is entered, **F.C. SBTL** and **F.C. Media** keys must be pressed to show the total amount in foreign currency. Then enter the foreign currency tendering amount and press the same **F.C. Media** key again.

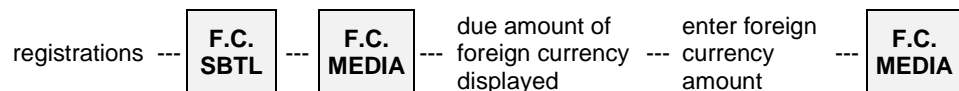

The change is calculated automatically in local currency if "automatic change" has been programmed. If "automatic change" has not been programmed, a designated media should be pressed for the change.

Direct Closing by Foreign Currency	
KEY ENTRY	RECEIPT
GERMAN WINE	GERMAN WINE 10.00
F.C. MEDIA	DUE AMOUNT 10.00
	0.9345 * 10.00
	FC MEDIA 1070
	due amount of local currency
	foreign currency rate x due amount of local currency
	foreign currency amount

Over-Tendering by Foreign Currency		
KEY ENTRY	DISPLAY (popped up)	RECEIPT
GERMAN WINE		GERMAN WINE 10.00
F.C. SBTL	FRGN C. ST 10.00	DUE AMOUNT 10.00
F.C. MEDIA	FRGN C. ST	0.9345 * 14.02 a
	FC MEDIA	FC MEDIA 1500 b
1500 F.C. MEDIA	FC MEDIA 1070	CHANGE 4.02 c
		a: tendering amount in local currency is calculated from tendering amount in foreign currency (1500 x 0.9345)
		b: tendering amount in foreign currency
		c: automatic change amount in local currency (430 x 0.9345)

## b) Currency Exchange

In order to exchange a foreign currency to the local currency, enter the foreign currency amount and press **F.C. Media** key at the beginning of a transaction. The ECR automatically subtracts a service charge amount which is calculated by a programmed charge rate (Z1/P-377).

The currency exchange operation is allowed depending on media function flag [MF-2.h] for TTL 1 ~ 24.

Currency Exchange	
KEY ENTRY	RECEIPT
30000	0.9345 * 280.35 a
F.C. MEDIA	FC MEDIA £30000 b
	CHARGE 5 % 14.02 c
	CHANGE 266.33 d

a: tendering amount in local currency is calculated from tendering amount in foreign currency (30000 x 0.9345)  
 b: tendering amount in foreign currency  
 c: currency exchange rate (key/symbol #14)  
 charge amount in local currency is calculated from the programmed charge rate (280.35 x 5%)  
 d: cashing amount in local currency

## c) Euro Currency System

A payment by the Euro currency is done by an **Euro media** key. When a transaction is closed by **Euro media** key, the due amounts in local and Euro currencies are printed on the receipt. If taxable items are included in the transaction, the Euro taxable amount and tax are also printed separately from the local taxable amount and tax. Euro amount is calculated by "local amount x Euro rate".

### < Display Method of Euro Currency System >

When **SBTL** key is pressed during a transaction, the display shows both local and Euro amount on the front display. On the rear display, it switches between Euro and local currencies in one second. Also, it can be manually switched by depression of **SBTL** key according to [SF-64.d] selection.



### < Print Formats of Euro Currency System >

Either "Euro and currency symbols are printed or not printed [SF-65.b]" and "one space or no space between Euro currency & currency symbols and the amount [SF-64.h]" can be selected by programming.

Note: Tax lines in local and Euro currencies are printed when "VAT data printed" [SF-22.h] is selected.

The receipt format will be like the following samples:

### 1. Direct Closing by Local Currency in Euro Currency System

Euro & currency symbols printed [SF-65.b=0]

PLU	10.00
DUE AMOUNT	DM 10.00
-----	
	€ 5.06
€ 1.00 =	DM 1.97719
-----	
CASH	DM 10.00
VATSALE	DM 9.10
VAT	DM 0.90
-----	
VATSALE	€ 4.60
VAT	€ 0.46

due amount (local)  
 --- only for reference ---  
 due amount (Euro) \*1  
 Euro currency exchange rate \*1  
 -----  
 directly closed by cash  
 VAT sales (local)  
 VAT amount (local)  
 --- only for reference ---  
 VAT sales (Euro) \*2  
 VAT amount (Euro) \*2

Euro & currency symbols not printed [b=1]

PLU	10.00
DUE AMOUNT	10.00
LOCAL	10.00
-----	
EURO	5.06
EURO 1.00 =	1.97719
-----	
CASH	10.00
VATSALE	9.10
VAT	0.90
-----	
VATSALE EURO	4.60
VAT EURO	0.46

- \*1 These are printed/displayed by [SF-65.a]. When "due amount in Euro currency printed/displayed" is selected, either "Euro currency exchange rate is printed/displayed or not printed/displayed [SF-65.d]" can be selected.
- \*2 These are printed by [SF-24.a].

### 2. Direct Closing by Euro Currency

Euro & currency symbols printed [SF-65.b=0]

PLU	10.00
DUE AMOUNT	DM 10.00
	€ 5.06
€ 1.00 =	DM 1.97719
EURO	€ 5.06
	( = DM 10.00 )
VATSALE	DM 9.10
VAT	DM 0.90
-----	
VATSALE	€ 4.60
VAT	€ 0.46

due amount (local)  
 due amount (Euro) always printed  
 \*1  
 directly closed by Euro  
 \*2  
 VAT sales (local) \*3  
 VAT amount (local) \*3  
 -----  
 VAT sales (Euro) \*3  
 VAT amount (Euro) \*3

Euro & currency symbols not printed [b=1]

PLU	10.00
DUE AMOUNT	10.00
LOCAL	10.00
EURO	5.06
EURO 1.00 =	1.97719
EURO	5.06
	( = 10.00 )
VATSALE	9.10
VAT	0.90
-----	
VATSALE EURO	4.60
VAT EURO	0.46

- \*1 Euro currency exchange rate is printed/displayed by [SF-65.d].
- \*2 Calculated amount in local currency is printed by [SF-64.e].
- \*3 These tax lines are printed by [SF-22.h].

### 3. Direct Closing by Foreign Currency in Euro Currency System

When "Foreign currency exchanged directly" [MF-1.h] is selected, the print format of foreign currency exchange rate will be as follows;

Foreign currency exchange rate =  
 Foreign currency / Local currency [MF-1.h=1]  
 Euro & currency symbols printed [SF-65.b=0]

PLU	10.00
DUE AMOUNT	DM 10.00
	FF 33.54
DM 1.00 * FF	3.353876
FRANC	FF 33.54
	( = DM 10.00 )
VATSALE	DM 9.10
VAT	DM 0.90

due amount (local)  
 due amount (foreign)  
 foreign currency exchange rate \*  
 directly closed by foreign currency  
 calculated amount in local currency

Foreign currency exchange rate =  
 Local currency / Foreign currency [MF-1.h=0]  
 Euro & currency symbols not printed [b=1]

PLU	10.00
DUE AMOUNT	10.00
LOCAL	10.00
	₣33.54
1.00 / ₣	0.298162
FRANC	₣33.54
	( = 10.00 )
VATSALE	9.10
VAT	0.90

- \* Foreign currency exchange rate is printed/displayed by [SF-65.c].

"Due amount in Euro currency and rate not printed/displayed" [SF-65.a] is selected on these samples.

## 10. Cheque Cashing / Cheque Printing

### a) Cheque Cashing

In order to exchange a Cheque for local currency, enter the cheque amount and press a **Media** key which has been programmed for cheque cashing [MF-2.h=1] at the beginning of a transaction. The ECR automatically subtracts a service charge amount which is calculated by using a programmed charge rate (Z1/P-377).

KEY ENTRY	RECEIPT	
1000	CHEQUE	10.00 $\text{¥}$ cheque amount
CHEQUE	CHARGE 10 % $\text{¥}$	1.00 $\text{¥}$ -- a
	CHANGE	9.00 cashing amount

a: cheque-cashing exchange rate (key/symbol #14), charge amount

### b) Cheque Printing on Slip Printer (TP-620)

A cheque is printed only when the transaction is closed by pressing a **Media** key which has been programmed for cheque depending on programming [SF-64.c].

The following contents are printed on a cheque using a slip printer (the print positions are programmable):

- cheque message (A)
- total amount in normal-size characters (B)
- total amount in double-width characters (C)
- date (D)
- ECR machine number, consecutive receipt number (E)

Depending on programming [SF-64.b], there are two ways to print a cheque.



#### 1. Manual cheque printing when a transaction is closed by Cheque Media key

Even if a cheque has not been set on the slip printer, the cheque printing data will be sent to the printer and a warning message will be displayed on both the ECR and the slip printer.

#### 2. Automatic cheque printing when a transaction is closed by Cheque Media key and a cheque has been inserted into the slip printer

In this case, if a cheque has not been set on the slip printer when pressing **Cheque Media** key, the cheque printing function will be **automatically canceled** and no warnings will appear.

#### Cheque Sample

	JOHN SMITH 6-22, Gion-Cho, Daito, Osaka, Japan	(B)	(D)	(E)
				*72.10* JUL07/2003 #001-000049
	(A)			\$ *72.10* (C)
<b>PAY TO THE ORDER OF</b>		<b>SAKURA CORP OSAKA JAPAN</b>		
		Seventy Two with 10/100 <span style="float: right;">DOLLARS</span>		
		The one the world can rely on. 3-5-25, Tenma, Kita-Ku, Osaka, Japan		
<b>FOR</b>				
124 100064 1004		55258 13 0276		

## 11. Tip Operation

A tip amount can be entered as either an amount separate from payment or as change from over-tendering.

### a) Tip Amount Input

registrations --- enter a tip amount --- **TIP** --- **TTL** --- close transaction or continue registration

KEY ENTRY	DISPLAY (popped up)	RECEIPT
BEER		BEER 3.00
T-BONE STEAK		T-BONE STEAK 25.00
50 TIP	TIP 0.50	TIP
CASH		CASH 0.50
CASH		CASH 28.00
		QUANTITY 2
		-----
		MEDIA&TIP
		CASH 28.50

printed by [SF-8.f]

**Note for Tip Media Amount Print**  
If the tip media and the tendering media are the same key like the key sequence above, the tip amount and the tendering amount are added together, then printed with a programmable message (key/symbol #76) by [SF-8.f].

### b) Change Kept As Tip

This function can not be done when the automatic change calculation has been programmed by [MF-2.e].

registrations --- **SBTL** --- enter the over-tendered amount --- **TTL** --- **TIP** --- **TTL**  
(change will be the tip)

KEY ENTRY	DISPLAY (popped up)	RECEIPT
BEER		BEER 3.00
T-BONE STEAK		T-BONE STEAK 26.50
SBTL		SBTL 29.50
3000 CASH		DUE AMOUNT 29.50
TIP	TIP 0.50	CASH 30.00
CASH		TIP 0.50
		QUANTITY 2
		-----
		MEDIA&TIP
		CASH 30.00

printed by [SF-8.f]

## 12. Mark-up / Mark-down

The key operation determines whether the mark-up/-down is calculated on the item or subtotal. For mark-up/-down on item, press % key immediately after the item is entered. For mark-up/-down on subtotal, press **SBTL** key before pressing % key.

The following depend on programming [SF-40~42];

- a manual rate entry is permitted or prohibited;
- mark-up/down amount always affects or does not affect the taxable subtotal;
- mark-up/down on item or on subtotal operation permitted or prohibited.

Only for the mark-down operation, you must turn the control key to the **Z1/P position** when [SF-32.f] is selected.

enter manual rate, if required --- Z1/P if required --- - %

<b>Mark-up (on item) : %1 key has been programmed for mark-up of 5%</b>	
KEY ENTRY	RECEIPT
BEER	BEER 2.50
ROAST BEEF	ROAST BEEF 14.00
%1	5 %
CASH	% 1 0.70
	CASH 17.20

<b>Mark-down (on subtotal) with manual rate entry: %2 key has been programmed for mark-down of 5%</b>	
KEY ENTRY	RECEIPT
BEER	BEER 2.50
ROAST BEEF	ROAST BEEF 14.00
SBTL	SBTL 16.50
4 %2	16.50 x 4 %2
CASH	% 2 0.66
	CASH 15.84

Subtotal printed by [SF-81.g].

### 13. Adjustment (Automatic % on Specific Items)

The adjustment function is provided for Membership discounts, Whole-sales prices, Employees, etc. Each PLU can be assigned to one of two adjustments by programming [PF-1.e,f]. Mark-up and Mark-down are presettable on each item, saving the trouble of manually entering rates. Adjustment amounts are shown on the full transaction report, but they will not affect PLU sales memory.

The depression of **ADJUST 1** key, **ADJUST 2** key or **ADJUST 1&2** key after entering items will calculate the mark-up/down amount. After an adjustment key depression, only a closing operation by a media key or NB (New Balance) key is permitted.

Depending on programming [SF-36, 37], adjustment amount affects or does not affect the taxable subtotal, and you must turn the control key to the **Z1/P position** when [SF-33.e,f] is selected.

<Example>

- ADJUST 1** Adjustment 1 key is used for price reduction (2%-)
- ADJUST 2** Adjustment 2 key is used for price reduction (5%-)
- ADJUST 1&2** Adjustment 1 & 2 key is used for price reduction (2%-, 5%-)

ADJUST 1 : CAKE = Adjustable 1 item, COFFEE = Adjustable 2 item	
KEY ENTRY	RECEIPT
CAKE	CAKE 1.50
COFFEE	COFFEE 1.00
ADJUST 1	1.50 X 2 % 0.03 0
CASH	AJST1 0.03 0
	CASH 2 . 47

adjustable 1 amount x adjustment 1 rate  
adjustment 1 amount

ADJUST 1&2 : CAKE = Adjustable 1 item, COFFEE = Adjustable 2 item	
KEY ENTRY	RECEIPT
CAKE	CAKE 1.50
COFFEE	COFFEE 1.00
ADJUST 1&2	1.50 X 2 % 0.03 0
CASH	AJST1 0.03 0
	1.00 X 5 % 0.05 0
	AJST2 0.05 0
	CASH 2 . 42

If an optional card reader is fitted and Adjustment Cards have been made by a card writer, Adjustment Cards also perform the adjustment automatically by swiping the card.

## 14. Amount Plus / Amount Discount

A plus/discount amount can be entered manually or the programmed amount is added/subtracted automatically.

The key operation determines whether the amount is added to the item or subtotal. For plus/discount on item, press (+) **or** (-) key immediately after the item is entered. For plus/discount on subtotal, press **SBTL** key before pressing (+) **or** (-) key.

The following depend on programming [SF-44, 45];

- plus/discount on item or on subtotal operation permitted or prohibited;
- plus/discount amount always affects or does not affect the taxable subtotal.

Only for the discount operation, you must turn the control key to the **Z1/P position** when [SF-32.e] is selected.

enter manual discount amount, --- Z1/P if required --- (-)  
if required

Amount discount operation on item : (-) key is programmed for 0.30 discount	
KEY ENTRY	RECEIPT
HAMBURGER	HAMBURGER 3.50
COFFEE	COFFEE 1.00
(-)	DSCNT 0.30
CASH	CASH 4.20

## 15. Last Item Correction

**CR** key is used to cancel the last-registered item (including function key).

Press **CR** key immediately after the wrong item or the wrong function key is registered. The corrected item is never printed on the post-receipt, kitchen printer and slip printer.

COFFEE is corrected.		
KEY ENTRY	DISPLAY	RECEIPT
CAKE		CAKE 1.50
COFFEE		COFFEE 1.00
CR	"CORRECTED" is displayed on	----- CORRECTED -----
CASH	the corrected item line.	CASH 1.50

PLU (HAMBURGER) with link PLU (COFFEE) is corrected.			
KEY ENTRY	DISPLAY	RECEIPT	
CAKE		CAKE 1.50	
HAMBURGER		HAMBURGER 3.50	
COFFEE		◆ COFFEE 1.00	
(link PLU)		----- CORRECTED -----	
CR	"CORRECTED" is displayed on	2 PS CORECT	number of corrected
CASH	the both of corrected main and link	CASH 1.50	items is printed
	PLUs.		

## 16. Void / Scroll Void

**VOID** key allows you to void an item registered in ongoing transaction. (In order to void an item registered by a series of key depression, the same key operation must be repeated.)

If a PLU has been registered for the items below, Scroll Void function is useful to void them. Scroll Void voids all these additional entries on the PLU automatically. So the same key operation is not required to repeat. Refer to the next page for the sequence.

Manual price entry, Multiplication, Split pricing, Square entry, Link PLU, Simple condiment PLU, Cooking message, Plus / Discount amount on item, % on item

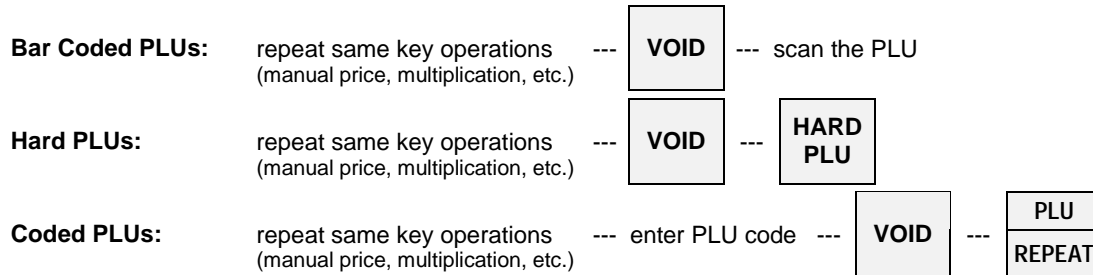

When [SF-32.d] is selected, you must turn the control key to the **Z1/P position** to allow voiding operations.

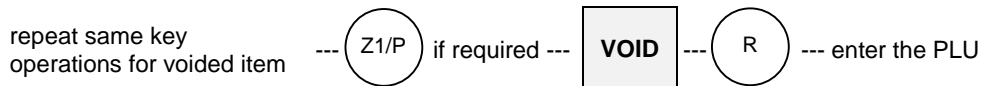

Two ICE CREAMs which are entered with manual prices are voided.

KEY ENTRY	DISPLAY	RECEIPT
100 ICE CREAM	<b>VOID</b>	ICE CREAM 1.00
CAKE	ICE CREAM 1.00	CAKE 1.50
100 ICE CREAM	CAKE 1.50	ICE CREAM 1.00
2 [X2]	ICE CREAM 1.00	2 X 1.00 ICE CREAM 2.00
100 VOID		↑↑↑↑↑↑↑↑↑↑ VOID ↑↑↑↑↑↑↑↑↑↑
ICE CREAM		CASH 1.50
CASH	<R > RECEIPT ON 3.50	
	Std Menu Std Price	
	ICE CREAM 1.00	
	CAKE 1.50	
	ICE CREAM 1.00	
	2 X ICE CREAM -2.00	
	<b>CASH 1.50</b>	
	<R > RECEIPT ON 0.00	

### < Kitchen Printer / Slip Printer >

The voided item is not printed on the kitchen printer and slip printer. Only the negative voided item (if permitted by [SF-31.c]) is printed in vertical double-width characters on the kitchen printer and in normal size on the slip printer with a minus symbol but with no void message.

### < Items in Item / Amount Track >

An item registered in an Item Track or an Amount Track (option) can be canceled by voiding the previous item at any time before it is closed by a media key.

## Scroll Void

During a transaction, you can **SCROLL** through or **PAGE UP/DOWN** to view all registered items and select items you wish to void.

1. During a transaction, press **SCROLL** or **PAGE UP/DOWN** key to enter scroll display mode.
2. Select an item you wish to void and press **VOID** key. (Press **CR** key to cancel the void selection.)  
To split the multiplied PLUs, enter the number of quantity you like to void and press **X2** and **VOID** keys. Multiplied PLUs entered by X2 key can be split to be voided. PLUs multiplied not by X2 key can be split only under "PLU consolidated" [SF-67.h=0] (can not be split under "PLU not consolidated" [SF-67.h=1]).
3. Selected items are finally voided by **ENTER** or **CASH/TTL 25** key by [SF-117.a].

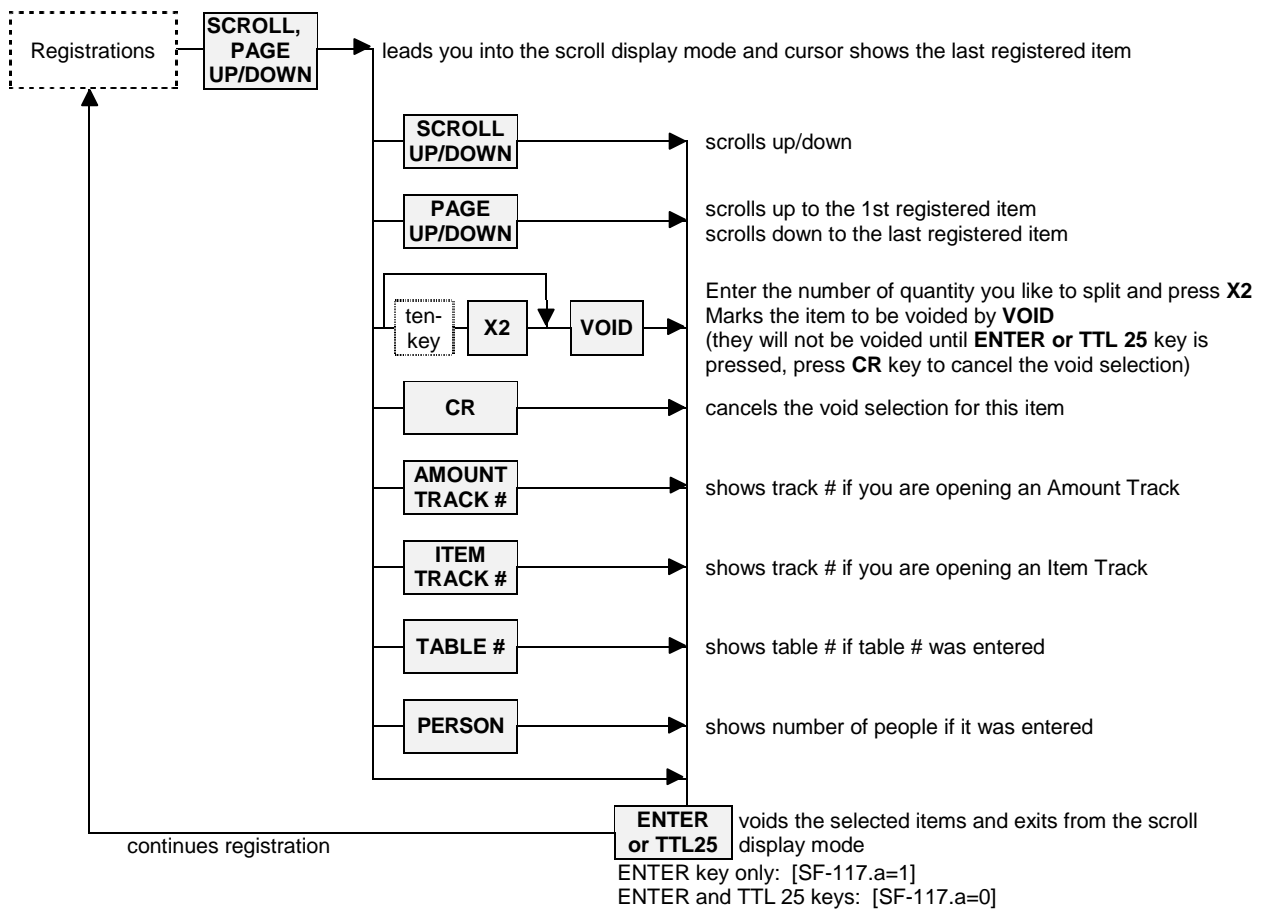

Scroll Void Operation Sequence																				
Two ICE CREAMS which are entered with a cooking message and manual price are voided.																				
KEY ENTRY	KEY EXPLANATION	RECEIPT																		
10 COOKING MESSAGE	cooking message entered	<table border="1"> <tr><td>2 X 1.00</td><td></td></tr> <tr><td>MINT ICE CREAM</td><td>2.00</td></tr> <tr><td>choco chip</td><td></td></tr> <tr><td>CAKE</td><td>1.50</td></tr> <tr><td>2 X 1.00</td><td></td></tr> <tr><td>MINT ICE CREAM</td><td>2.00</td></tr> <tr><td>choco chip</td><td></td></tr> <tr><td>↑↑↑↑↑↑↑↑↑↑ VOID ↑↑↑↑↑↑↑↑↑↑</td><td></td></tr> <tr><td>CASH</td><td>1.50</td></tr> </table>	2 X 1.00		MINT ICE CREAM	2.00	choco chip		CAKE	1.50	2 X 1.00		MINT ICE CREAM	2.00	choco chip		↑↑↑↑↑↑↑↑↑↑ VOID ↑↑↑↑↑↑↑↑↑↑		CASH	1.50
2 X 1.00																				
MINT ICE CREAM	2.00																			
choco chip																				
CAKE	1.50																			
2 X 1.00																				
MINT ICE CREAM	2.00																			
choco chip																				
↑↑↑↑↑↑↑↑↑↑ VOID ↑↑↑↑↑↑↑↑↑↑																				
CASH	1.50																			
2 [X2] 100	multiplication and manual price entry are done																			
MINT ICE CREAM																				
CAKE																				
SCROLL, PAGE UP/DOWN	(1) enters into the scroll display mode																			
SCROLL UP	(2) moves cursor to 2 X MINT ICE CREAM																			
SCROLL UP																				
VOID	(3) Marks item to be voided ("VOID" is displayed on the item to be voided.) No need to repeat the entries of cooking message, multiplication and manual price entry.																			
ENTER (or TTL 25)	(4) voids the selected items and exits from the scroll display mode																			
CASH																				

Multiplied PLUs can be split for scroll void. Enter the number of quantity you would like to split void and press **X2** and **VOID** keys.

Scroll Void Operation Sequence												
One of two ICE CREAMS is voided.												
KEY ENTRY	KEY EXPLANATION	RECEIPT										
2 [X2] 100 ICE CREAM	multiplication and manual price entry are done	<table border="1"> <tr><td>2 X 1.00 ICE CREAM</td><td>2.00</td></tr> <tr><td>CAKE</td><td>1.50</td></tr> <tr><td>ICE CREAM</td><td>1.00</td></tr> <tr><td>↑↑↑↑↑↑↑↑↑↑ VOID ↑↑↑↑↑↑↑↑↑↑</td><td></td></tr> <tr><td>CASH</td><td>2.50</td></tr> </table>	2 X 1.00 ICE CREAM	2.00	CAKE	1.50	ICE CREAM	1.00	↑↑↑↑↑↑↑↑↑↑ VOID ↑↑↑↑↑↑↑↑↑↑		CASH	2.50
2 X 1.00 ICE CREAM	2.00											
CAKE	1.50											
ICE CREAM	1.00											
↑↑↑↑↑↑↑↑↑↑ VOID ↑↑↑↑↑↑↑↑↑↑												
CASH	2.50											
CAKE												
SCROLL, PAGE UP/DOWN	(1) enters into the scroll display mode											
SCROLL UP	(2) moves cursor to "2 X ICE CREAM"											
1 [X2] VOID	(3) enters the number of quantity you like to split (quantity of item voided popped up)											
ENTER (or TTL 25)	(4) voids the selected items and exits from the scroll display mode											
CASH												

< Notes for Scroll Void >

If a PLU has been registered with the following items, all of these additional entries on the PLU are also selected automatically as void items;

- manual price entry, split pricing, square entry
- link PLU, simple condiment PLU, cooking message
- plus / discount amount on item, % on item

If the following operations on subtotal have been done, selecting void items are not operational until those operations are voided first;

- plus / discount amount on subtotal, % on subtotal, adjustment

If the following operations have been done, selecting void items are no longer operational;

- manual tax entry, tax exemption, tendering amount entry

Message entry (not cooking message) only can be selected for the void operation.

PLUs multiplied not by X2 key can be split for scroll void only under "PLU consolidated" [SF-67.h=0] (can not be split under "PLU not consolidated" [SF-67.h=1]).

## 17. Transaction Void

Transaction Void can be done if you wish to cancel all the registrations in a transaction.

**This is available only before the transaction is closed.**

In order to cancel all the registrations, simply press **TRANSACTION VOID** key.

Then, the ECR shows Warning Message #45 (means "Are you sure to execute Transaction Void?").

Press **CASH/TTL 25** key to execute it or press **TRANSACTION VOID** key again to cancel it.

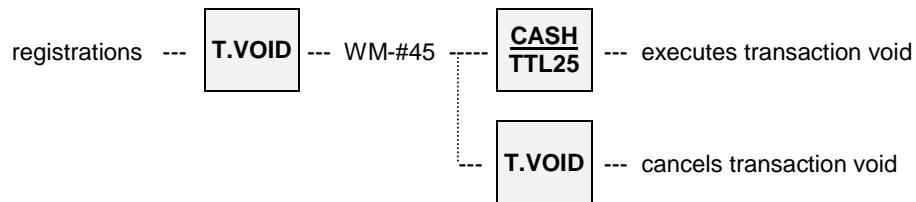

When [SF-32.d] is selected, you must turn the control key to the **Z1/P position** to allow transaction void.

Transaction Void	
KEY ENTRY	DISPLAY (on the top)
ICE CREAM	
CAKE	
T.VOID	WM-#45
CASH/TTL 25	

  

RECEIPT	
ICE CREAM	1.00
CAKE	1.50
↑↑↑↑↑↑↑↑↑↑ T.VOID ↑↑↑↑↑↑↑↑↑↑	

## 18. Refund / Media Refund

**REFUND** key is used to refund a registered item after the transaction has been closed. The ECR will not check to see if the refunded item was actually registered except the case of item track operation before the track is closed by a media key.

In order to refund an item registered by a series of key depression, the same key operation must be repeated. Press **REFUND** key after entering the data (PLU code, manual price, etc.).

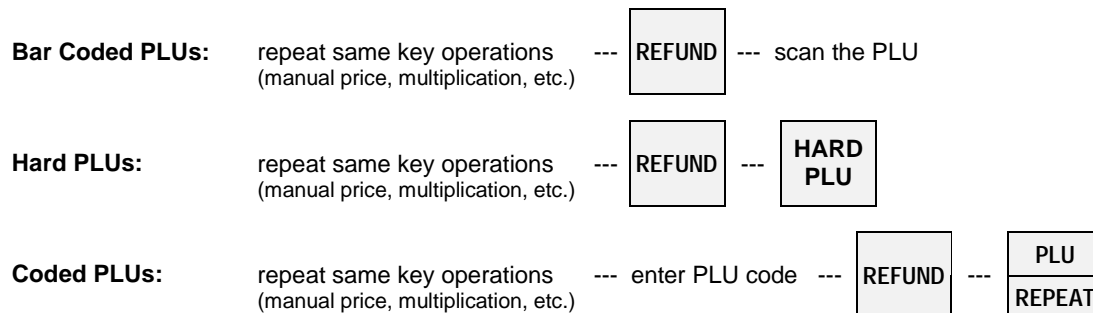

When [SF-32.c] is selected, you must turn the control key to the **Z1/P position** to do refund operation.

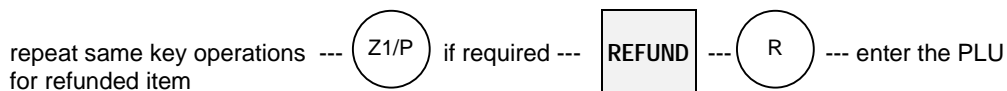

ORANGE JUICE is refunded.

<p>KEY ENTRY REFUND ORANGE JUICE CASH</p>	<table border="1" style="width: 100%; border-collapse: collapse;"> <tr> <th colspan="2" style="text-align: left;">RECEIPT</th> </tr> <tr> <td style="width: 70%;">ORANGE JUICE</td> <td style="width: 30%; text-align: right;">2.00</td> </tr> <tr> <td colspan="2" style="text-align: center;">↑↑↑↑↑↑↑↑↑↑ REFND ↑↑↑↑↑↑↑↑↑↑</td> </tr> <tr> <td>CASH</td> <td style="text-align: right;">2.00⊕</td> </tr> </table> <p style="text-align: center;">KITCHEN PRINTER</p> <table border="1" style="width: 100%; border-collapse: collapse;"> <tr> <td style="text-align: center;"> <p>ECR NO.1 --&gt; BAR CLERK NAME 00001</p> <p style="font-size: 1.5em; font-weight: bold;">1⊕ ORANGE JUICE</p> <p style="font-size: 0.8em;">JUL03/2003#001-000060 11:11</p> </td> </tr> </table> <p style="text-align: center;">SLIP PRINTER</p> <table border="1" style="width: 100%; border-collapse: collapse;"> <tr> <td colspan="2" style="text-align: left;">Served by CLERK NAME 00001</td> </tr> <tr> <td style="width: 70%;">ORANGE JUICE</td> <td style="width: 30%; text-align: right;">2.00⊕</td> </tr> <tr> <td>CASH</td> <td style="text-align: right;">2.00⊕</td> </tr> <tr> <td colspan="2" style="font-size: 0.8em;">JUL03/2003#001-000060 R CLERK NAME 00001</td> </tr> </table>	RECEIPT		ORANGE JUICE	2.00	↑↑↑↑↑↑↑↑↑↑ REFND ↑↑↑↑↑↑↑↑↑↑		CASH	2.00⊕	<p>ECR NO.1 --&gt; BAR CLERK NAME 00001</p> <p style="font-size: 1.5em; font-weight: bold;">1⊕ ORANGE JUICE</p> <p style="font-size: 0.8em;">JUL03/2003#001-000060 11:11</p>	Served by CLERK NAME 00001		ORANGE JUICE	2.00⊕	CASH	2.00⊕	JUL03/2003#001-000060 R CLERK NAME 00001	
RECEIPT																		
ORANGE JUICE	2.00																	
↑↑↑↑↑↑↑↑↑↑ REFND ↑↑↑↑↑↑↑↑↑↑																		
CASH	2.00⊕																	
<p>ECR NO.1 --&gt; BAR CLERK NAME 00001</p> <p style="font-size: 1.5em; font-weight: bold;">1⊕ ORANGE JUICE</p> <p style="font-size: 0.8em;">JUL03/2003#001-000060 11:11</p>																		
Served by CLERK NAME 00001																		
ORANGE JUICE	2.00⊕																	
CASH	2.00⊕																	
JUL03/2003#001-000060 R CLERK NAME 00001																		

The refunded item is printed in double-height and width characters on the kitchen printer and in normal size on the slip printer with a minus symbol but with no refund message.

## Refund of Transaction with Subtotal Discount

Refund with Subtotal Discount can be done by the following operation. **REFUND** key must be pressed before **AMOUNT (-)** key. **AMOUNT (+)** key is pressed in case of refund with Subtotal Plus.

1. Refund all items.
2. Press SBTL key.
3. Enter discount amount (if necessary) and press **REFUND** and **AMOUNT (-)** keys.
4. Close the transaction by pressing **TOTAL** (media) key.

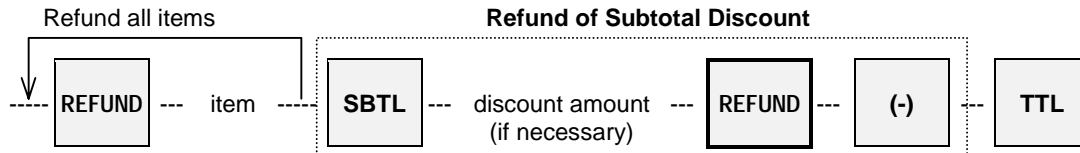

Refund including Subtotal Discount		ORIGINAL RECEIPT
KEY ENTRY	EXPLANATION	(before refund with subtotal discount)
REFUND BEER		BEER 2.50
REFUND WHITE WINE		WHITE WINE 5.00
SBTL	subtotal amount (-7.50) popped up	SUBTOTAL 7.50
50 REFUND (-)	enter discount amount and press <b>REFUND</b> and	DSCNT 0.50
CASH	<b>(-)</b> keys	CASH 7.00

Receipt printed real time [SF-4.h=0]

BEER	2.50
↑↑↑↑↑↑↑↑↑↑ REFND ↑↑↑↑↑↑↑↑↑↑	
WHITE WINE	5.00
↑↑↑↑↑↑↑↑↑↑ REFND ↑↑↑↑↑↑↑↑↑↑	
SUBTOTAL	7.50
DSCNT	0.50
↑↑↑↑↑↑↑↑↑↑ REFND ↑↑↑↑↑↑↑↑↑↑	
CASH	7.00

Printed after transaction is closed [SF-4.h=1]

BEER	2.50
WHITE WINE	5.00
SUBTOTAL	7.50
DSCNT	0.50
CASH	7.00

Note: Subtotal is NOT printed when "receipt printed after closing" [SF-4.h=1] is selected under Non-Clerk Interrupt System [SF-12.a=0], even if "subtotal printed by SBTL key" [SF-81.g=1] is selected.

## Refund with Item Discount

Refund with item discount can be done by the following operation. **NOT** necessary to press **REFUND** key before **AMOUNT (-)** key. **AMOUNT (+)** key is pressed in case of refund with Item Plus.

1. Refund item.
2. Enter discount amount (if necessary) and press **AMOUNT (-)** key.

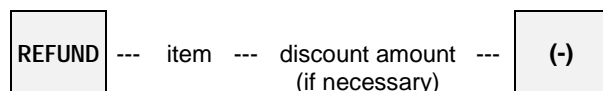

The same operational sequence applies to refund with % or Adjustment by pressing equivalent keys after "Refund item".

## Media Refund

This function is useful when you wish to refund a registered item in the transaction closed by plural media keys. It is not required to do if the transaction was closed by one media key.

By this operation, the refunded amounts are subtracted from the respective media memory, but they are not memorized in the refund memory.

For example, when the transaction below is required to refund, then the operation sequence will be;

PLU-NAME 0001	1.00
PLU-NAME 0002	2.00
SBTL	3.00
DUE AMOUNT	3 . 00
CASH	1.00 <sup>2</sup>
CHECK	2.00

KEY ENTRY	RECEIPT
REFUND	PLU-NAME 0001 1.00
PLU 1	↑↑↑↑↑↑↑↑ REFND ↑↑↑↑↑↑↑↑
REFUND	PLU-NAME 0002 2.00
PLU 2	↑↑↑↑↑↑↑↑ REFND ↑↑↑↑↑↑↑↑
MEDIA REFUND	DUE AMOUNT 3 . 00 <sup>2</sup>
100 CASH	CASH 1.00 <sup>2</sup>
MEDIA REFUND	↑↑↑↑↑↑↑↑ REFND ↑↑↑↑↑↑↑↑
CHECK	CHECK 2.00 <sup>2</sup>
	media refund

## 19. Tax

Each PLU can have one of four taxes and they are calculated by either VAT method or Add-On Tax method.

### VAT Method [SF-21.e~f=0]

Tax amount is included in the price. The tax shift is available however, manual tax amount entry and manual tax exemption are not available.

### Add-On Tax Method [SF-21.e~f=1]

Tax amount is charged separately from the price. **Tax Rate or Tax Table** selection is available for each tax by [SF-21.a~d]. The tax shift, manual tax amount entry and manual tax exemption are available.

The following items can be printed by programming:

- tax symbol printed or not printed [SF-22.d]
- taxable subtotal amount printed or not printed [SF-22.e]
- tax amount printed even if tax = 0 or not printed [SF-22.f]
- tax amounts printed separately or consolidated on one line [SF-22.g]
- VAT data printed or not printed (add-on tax data always printed) [SF-22.h]
- VAT taxable subtotal printed with tax or without tax [SF-22.c]

The following operations are possible **only for the add-on tax items**:

<b>Taxable Subtotal Display</b>			
PLU entry ---	<table border="1"><tr><td><b>TAX SHIFT 1 ~ 4</b></td></tr></table> --- <table border="1"><tr><td><b>SBTL</b></td></tr></table>	<b>TAX SHIFT 1 ~ 4</b>	<b>SBTL</b>
<b>TAX SHIFT 1 ~ 4</b>			
<b>SBTL</b>			
	The taxable subtotal is popped up by using the proper <b>TAX SHIFT</b> key and <b>SBTL</b> key immediately after registering the PLU.		

Display Example  
(popped up)

<b>TAX 2</b>	→	<b>TXSL2</b> 2.00
--------------	---	----------------------

<b>Net Subtotal Display</b>		
PLU entry ---	<table border="1"><tr><td><b>NET SBTL</b></td></tr></table>	<b>NET SBTL</b>
<b>NET SBTL</b>		
	Net subtotal without add-on tax amount is popped up. The amount is printed by [SF-81.c].	

**Manual Tax Entry** After it is performed, all other operations are prohibited, except for a media closing.

PLU entry --- manual tax amount --- **TAX** --- **TAX SHIFT 1 ~ 4**

Display Example  
(popped up)

**TAX** 0.20 → **TAX 2** 0.20

RECEIPT

PLU-NAME 0001	1.00	non-taxable item
PLU-NAME 0002	2.00	taxable 2 item
TXSL2	2.00	
TAX 2	0.20	manual tax
CASH	3.20	

**Manual Tax Exemption** (available if permitted by programming [SF-23])

PLU entry --- **TAX SHIFT 1 ~ 4** --- **TAX**

This may be used at the end of a transaction to exempt the whole transaction from a particular tax rate, e.g. the whole sale could be exempted from Tax 2.  
After it is performed, all other operations are prohibited, except for a media closing.

Display Example  
(popped up)

**TAX 2** → **TAX 2 EXEMPT**

RECEIPT

PLU-NAME 0001	1.00	non-taxable item
PLU-NAME 0002	2.00	taxable 2 item
TXSL2	2.00	
TAX 2-----	0.00	tax 2 exempted manually
CASH	3.00	

< **Automatic Tax Exemption for Add-On Tax System** >

If the tax exemption limit amount is programmed by PGM-108, the tax amount is automatically exempted according to the taxable subtotal amount per entered number of people or per transaction by [SF-23.e~h].

RECEIPT

PLU-NAME 0001	1.00	
PLU-NAME 0002	2.00	taxable 2 item
TXSL2	2.00	
TAX 2	0.00	tax 2 exempted automatically
CASH	3.00	

**< Tax Shift >**

It is possible for both the VAT tax items and the add-on tax items:  
Tax status is changed by **TAX SHIFT 1 ~ 4** keys.

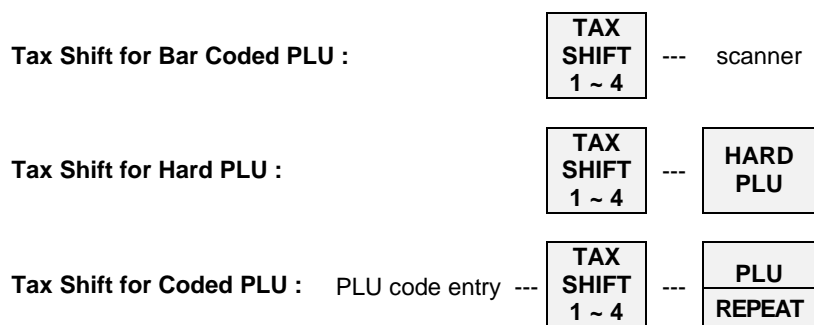

**i) TAX SHIFT ON VAT TAX ITEMS**

Depression of a tax shift key changes a tax status to a different VAT tax status.

	<b>TAX SHIFT KEY PRESSED</b>			
	TAX SHIFT 1 key	TAX SHIFT 2 key	TAX SHIFT 3 key	TAX SHIFT 4 key
Non-taxable & VAT taxable items are changed to ...	taxable 1	taxable 2	taxable 3	taxable 4

**ii) TAX SHIFT ON ADD-ON TAX ITEMS**

Tax shift can also be used with the add-on tax items but in a way which is different from the VAT items. If the pressed TAX SHIFT key number and the item's tax number are the same, the item will become non-taxable. If the pressed TAX SHIFT key number and the item's tax number are different, the tax status will be both the original item's tax status and the shifted tax status as follows:

<b>ADD-ON TAX STATUS</b>	<b>TAX SHIFT KEY PRESSED</b>			
	TAX SHIFT 1 key	TAX SHIFT 2 key	TAX SHIFT 3 key	TAX SHIFT 4 key
Non-taxable item	taxable 1	taxable 2	taxable 3	taxable 4
TAXABLE 1 ITEM	non-taxable	1, 2	1, 3	1, 4
TAXABLE 2 ITEM	taxable 1, 2	non-taxable	2, 3	2, 4
:	:	:	:	:
TAXABLE 1 & 2 ITEM	2	1	1, 2, 3	1, 2, 4
TAXABLE 1 ~ 4 ITEM	2, 3, 4	1, 3, 4	1, 2, 4	1, 2, 3

The function of TAX SHIFT keys depends on which tax method is selected for each of the four taxes. Tax shift for the VAT system affects only VAT tax items and tax shift for the add-on system affects only add-on tax items. For example, Tax 1 and 2 are VAT method, tax 3 and 4 are add-on tax method, PLU 1's tax status is tax 1 & 3:

<b>PLU 1's TAX STATUS</b>	<b>TAX SHIFT KEY PRESSED</b>			
	TAX SHIFT 1 key (VAT)	TAX SHIFT 2 key (VAT)	TAX SHIFT 3 key (add-on tax)	TAX SHIFT 4 key (add-on tax)
TAX 1 (VAT method)	no change	taxable 2	no change	no change
TAX 3 (add-on tax method)	no change	no change	non-taxable	taxable 3 & 4
<b>PLU1's tax status will be</b>	<b>taxable 1 &amp; 3</b>	<b>taxable 2 &amp; 3</b>	<b>taxable 1</b>	<b>taxable 1, 3, 4</b>

## 20. R/A (Received on Account)

This function is used to record an amount of money received into the cash drawer outside of sales (i.e. in order to register the money prepared for change into the ECR memory).

50.00 x 1 piece and 5.00 x 10 pieces are entered								
KEY ENTRY	DISPLAY (on the top)	RECEIPT						
R/A	R/A	<table> <tr> <td>CASH</td> <td style="text-align: right;">50.00</td> </tr> <tr> <td>CASH</td> <td style="text-align: right;">50.00</td> </tr> <tr> <td>R/A</td> <td style="text-align: right;">100.00</td> </tr> </table>	CASH	50.00	CASH	50.00	R/A	100.00
CASH	50.00							
CASH	50.00							
R/A	100.00							
5000 CASH								
10 [X2]								
PRESET TENDER 1								
R/A		Media multiplication can only be done using a preset tender media key. <b>PRESET TENDER 1</b> key has been assigned to CASH/TTL 25 memory by SP-253.						

## 21. P/O (Paid Out)

This function is used to record an amount of money withdrawn from the cash drawer.

50.00 is withdrawn.						
KEY ENTRY	DISPLAY (on the top)	RECEIPT				
P/O	P/O	<table> <tr> <td>CASH</td> <td style="text-align: right;">50.00</td> </tr> <tr> <td>P/O</td> <td style="text-align: right;">50.00</td> </tr> </table>	CASH	50.00	P/O	50.00
CASH	50.00					
P/O	50.00					
5000 CASH						
P/O						

## 22. No Sale

This function is used to open the drawer outside of sales. Simply press **NO SALE** key. (When [SF-32.g] is selected, you must turn the control key to the **X position** to use this operation.)

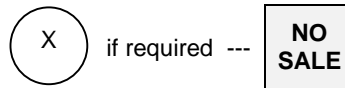

KEY ENTRY	RECEIPT
NO SALE	NSALE 0.00

No sale operation is not printed on receipt (printed on journal) in order to save paper if [SF-5.f] is selected.

### "0.00" or ".00" Print and Display

You can choose ".00" or ". 0" for display by the media flag selection [MF-2.b] and "0.00" by [MF-4.a].

	DISPLAY	RECEIPT
[MF-2.b=0, MF-4.a=1]	0.00	NSALE 0.00
[MF-2.b=0, MF-4.a=0]	.00	NSALE .00
[MF-2.b=1]	. 0	NSALE . 0

## 23. Off Compulsory

**OFF COMPULSORY** key is used for the temporary release of all compulsory conditions.

For example, under a track number entry compulsory condition, press **OFF COMPULSORY** key at the beginning of a transaction for release of the compulsory condition.

(When [SF-33.g] is selected, you must turn the control key to the **Z1/P position** to use OFF COMPULSORY function.)

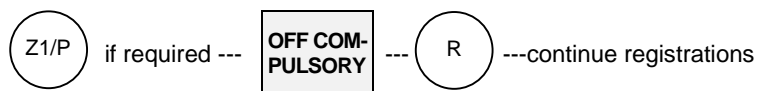

## 24. Number of People

Up to 99 people can be entered with **PERSON** key to indicate the number of customer. Additional entry is overridden (not added).

enter the number of people --- **PERSON**



KEY ENTRY	DISPLAY (popped up)	RECEIPT	
2 PERSON	PERSN 2	Non-Clerk Interrupt System	
BEER		BEER 2.50	
RED WINE		RED WINE 3.00	
CASH		CASH 5.50	
		QUANTITY 2	number of people
		PERSN 2	
		Clerk Interrupt System	
		<O1> 2	number of people
		BEER 2.50	
		RED WINE 3.00	
		CASH 5.50	
		QUANTITY 2	
		POST-RECEIPT	
BUFFER PRINT		Served by CLERK NAME 00001 2	number of people
		BEER 2.50	
		RED WINE 3.00	
		CASH 5.50	
		QUANTITY 2	

If a post-receipt is printed by **BUFFER PRINT** key in the receipt off condition, number of people is printed at right of the clerk name.



## 26. Slip Validation (TP-620 only)

Validation on the ECR's internal printer is not available, however the slip validation is available.

Validation on the slip printer is available if the ECR is programmed for use with a slip printer TP-620. Insert a slip paper before **VALIDATION** key is pressed.

They can be issued for any item after it is registered, any media after payment is made, or for the total after the transaction is closed.

### Item & Media Validations:

insert validation paper after an item or a media is registered ---

<b>MEDIA / ITEM VALID.</b>
------------------------------------

### Total Validations:

insert validation paper after a transaction is closed ---

<b>TOTAL VALID.</b>
-------------------------

KEY ENTRY	RECEIPT	
BEER 6 BOTTLES	BEER 6 BOTTLES	6.60
	CASH	6.60
insert a paper for item slip validation		
MEDIA/ITEM VALID.	JUL15/2003#002-0001 BEER 6 BOTTLES	6.60
CASH		
insert a paper for media slip validation		
MEDIA/ITEM VALID.	JUL15/2003#002-0001 CASH	6.60
insert a paper for total slip validation		
TOTAL VALID.	JUL15/2003#002-0001 AMONT	6.60
		key/symbol#35
	JUL15/2003#002-0001 11:43 AMONT	6.60
	time printed by [SF-9.a]	

The following depend on programming by [SF-9]:

- Slip validation is compulsory or is not compulsory
- Slip validation can be printed only one time or an unlimited number of times
- Time printed or not printed
- Slip validation with slip upper logo [SF-82]

## 27. Arrangement

There are four kinds of arrangement keys. Up to 50-key steps operations can be assigned to each one of the **ARRANGEMENT 1 ~ 10** key.

Example 1: **ARRANGEMENT 1** key is programmed for an automatic discount and closing operations as follows:

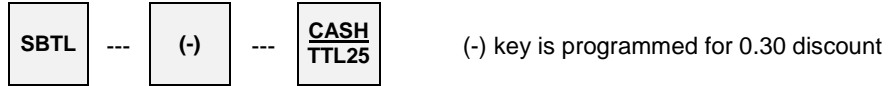

KEY ENTRY	RECEIPT
SALMON STEAK	SALMON STEAK                    15.00
ARRANGEMENT 1	SBTL                                15.00
	DSCNT                            0.30 <del>0</del>
	CASH                              14.70

Example 2: **ARRANGEMENT 2** key is programmed for assorted reports.

X-03 Full Transaction report (3, X2, TTL25)

X-05 Hourly report (5, X2, TTL25)

X-10 Clerk report (1, 0, X2, TTL25)

### Operation

Turn the control key to the **X position** and press **ARRANGEMENT 2** key. Then, above reports will automatically be printed.

## 28. Recall

The total amount of the last transaction **which has been closed directly by a media key** can be recalled by **RECALL** key. A transaction which has been closed with amount tendered can not be recalled.

The recalled transaction must be closed by a media key with a tendering amount entry. It can be canceled by **CL** key.

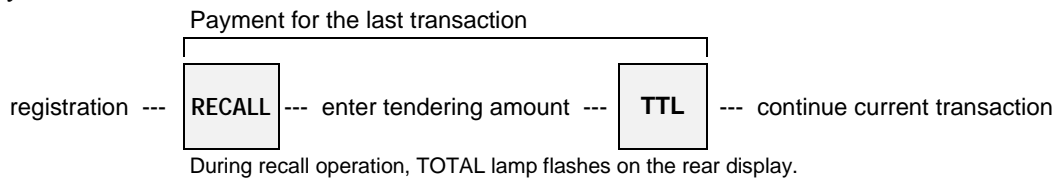

### Recall of the transaction which is closed by a foreign currency media

When the last transaction is recalled, the closed foreign currency media key name and the total amount in local currency is displayed. Before entering the foreign currency tendering amount for the last transaction, **F.C. SBTL** key and the specific foreign currency media key must be pressed.

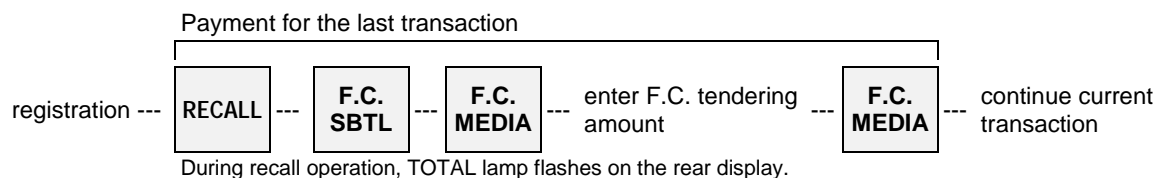

The last transaction is recalled during the current transaction		
KEY ENTRY	DISPLAY	
(current transaction)	(current transaction)	RECEIPT (last transaction)
TOMATO CAN		SALMON STEAK 11.00
SAUSAGE		MILK 2.00
		CASH 13.00
RECALL	<div style="background-color: blue; color: white; padding: 2px;">           RECALL            CASH            13.00         </div>	the last transaction's total amount is recalled
1500 CASH *	<div style="background-color: blue; color: white; padding: 2px;">           CHANGE            2.00         </div>	change amount for the last transaction is popped up
* Tendering amount input compulsory. If the automatic change is not programmed, a designated media must be pressed to calculate the change.		
(continue the current transaction)		RECEIPT (current transaction)
TUNA CAN		TOMATO CAN 5.00
CASH		SAUSAGE 4.00
		TUNA CAN 3.00
		CASH 12.00

## 29. Track System - Item Track / Amount Track

Following contents are described in this section:

Two Track Systems

Two Track Number Entry Methods

Two Clerk Track Assignment Methods

Note for Item / Amount Track System used with Clerk Interrupt System

Track Operation Sequences

- *Two Track Systems --- Item and Amount Track Systems can be used at the same time.*

	Item Track System	Amount Track System (optional memory board required)
Characteristics	<ul style="list-style-type: none"> <li>- Track is identified by Item Track # (7 digits).</li> <li>- Records detailed registration contents.</li> <li>- Track can be temporarily closed by using <b>NB</b> (New Balance) key, until finally closed by a media key.</li> <li>- Tax is printed each time the track is closed or it is printed only when the track is finally closed by a <b>Media</b> key by [SF-16.g].</li> </ul>	<ul style="list-style-type: none"> <li>- by Amount Track # (7 digits)</li> <li>- Records only transaction totals.</li> <li>- Track can be temporarily closed by using <b>CHARGE</b> key, until finally closed by a media key.</li> <li>- Tax is printed each time the track is closed.</li> </ul>
# of Items/Track	Registers up to 359 items. (item includes tax data, transaction data)	Not available
# of Tracks	See the explanation of Warning Message #34. (# of tracks handled will change depending on the # of registered items)	4681 tracks
Track # Entry	One of Automatic or Manual Track # Method is used by [SF-15.a].	Manual Track # Method is used.
Track # Display	Displayed/printed in brackets < Item Track >	Displayed/printed in brackets << Amount Track >>
Table Assignment (4-digit table #)	Available when Automatic Item Track # Method is used by [SF15.a=0]. Also available when Manual Track # Method [SF-15.a=1] is used under Clerk Interrupt System [SF-12.a=1]. Displayed/printed in brackets * table # *	Not available (Although it can be entered and printed on a receipt under Clerk Interrupt System, the table number is not memorized.)
Pick-Up by Table #	Available only under Non-Clerk Interrupt System [SF-12.a=0].	Not available
Clerk Track Assignment	Available	Not available
Post-Bill	Shows the last transaction contents immediately after the track is closed by pressing <b>BUFFER PRINT</b> key. This can be used as a Check-Out Bill if Post-Bill is issued each time the track is closed.	
Subtotal Bill	Temporarily closed Item Track contents printed by <b>CHECK-OUT BILL</b> key. This is used to check the track contents and it can be used as a Check-Out Bill if programmed by [SF-83.a,b].	Not available
Check-Out Bill	Entire contents of finally closed Item Track printed by <b>CHECK-OUT BILL</b> key.	Not available
Track Transfer	Available	Available

• **Two Track Number Entry Methods**

One of the two track number entry methods can be programmed for Item Track System. For Amount Track System, the track number must always be entered manually.

**1) Automatic Item Track Number Method (Item Track System Only)**

If this method is programmed by [SF-15.a=0], Item Track is automatically assigned in sequential order by pressing **ITEM TRACK #** key. The digit and value of track number are programmable (up to 9999999) by [SF-14].

**< Unique Automatic Track # [SF-14.a=1] >**

Depending on programming [SF-14.a=1], the last two digits of the ECR machine number (ECR ID) are put to the head of the automatic 1 ~ 5 digits item track number. This makes the item track number unique.

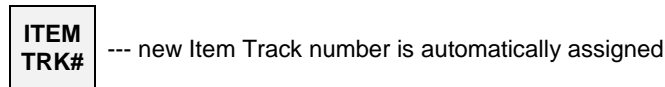

When a track is finally closed by a media key, that track number can not be used again. When a track number goes up to a programmed maximum number, the next track number will begin from 1. At that time, track numbers which are not closed will be skipped.

A table number (allocating where customers sit) can be assigned and the track can be picked up by the table number under non-clerk interrupt system.

**2) Manual Track Number Method (Item / Amount Track Systems)**

The track is assigned by manually entering a random 1 ~ 7 digit track number with the depression of **ITEM TRACK #** key or **AMOUNT TRACK #** key.

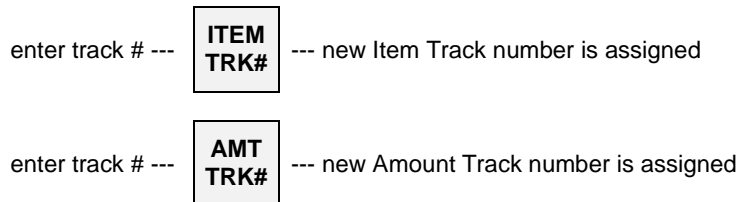

After a track is finally closed by a media key, the track number can be used again.

A table number assignment is available only for Item Track System under the clerk interrupt system is used but the track **can not** be picked up by the table number. Although a table number can be entered and printed on a receipt under the clerk interrupt system, but the table number is not memorized for Amount Track System.

- ***Clerk Track Assignment Methods (Item Track System Only)***

- 1) **Free Clerk Track Assignment [SF-16.a=0]**

Any clerk can open, access and close any track.

- 2) **Clerk Track Assignment in Registration [SF-16.a=1]**

Any clerk may open a new track, however, subsequent entries to the track is only authorized to the clerk who originally opened the track.

\* **Manager Help Function**

Only the designated manager clerk can access any clerk's item track which was assigned to the clerk in a registration. When the manager clerk picks up or closes the item track which was opened by other clerk, the registered items are memorized in the item track memory and the previously assigned clerk's memory. These are not memorized in the manager clerk's memory.

- ***Note for Item / Amount Track System used with Clerk Interrupt System***

- 1) **Track Assignment**

When a clerk opens a track, it is memorized in each track memory instead of in the clerk's interrupt memory.

- 2) **Track Auto-Closing by Clerk Interrupt**

If the clerk is interrupted by other clerk, the assigned track is automatically closed by **NB** (New Balance) key or **CHARGE** key and the track contents are automatically printed on a receipt in the receipt-on condition.

The temporarily closed tracks can be opened by entering the track numbers with **ITEM TRACK #** key or **AMOUNT TRACK #** key but they are not opened by the clerk entry.

- 3) **Table # Assignment**

If it is the Item Track, the entered table number is assigned to the track. But the Item Track can not be picked up by the assigned table number in the clerk interrupt system.

If it is the Amount Track, the table number can not be used. Although it can be entered and printed on a receipt, the table number is not memorized.

- ***Track Operation Sequences***

- A. Item Track System**

- a) Opening a New Track & Closing Temporarily
  - < Opening a New Item Track >
  - < Closing an Item Track Temporarily >
  - < Issuing a Post-Bill and/or Subtotal Bill >
- b) Picking Up a Track & Closing a Track Finally
  - < Picking Up an Item Track >
  - < Closing an Item Track Finally >
  - < Issuing a Check-Out Bill >
- c) Table # Assigned to an Item Track
  - < Assigning a Table Number to an Item Track >
  - < Assigning a Table Number to a Multiple Number of Tracks >
  - < Picking Up an Item Track by Table Number >
- d) Track Transfer to a New Track or a Designated Track
- e) Item Transfer to Item Track in Scroll Display Mode
- f) Item Track Transfer to Amount Track (optional memory board required)
- g) Item Track Balance Calculation (display only)
  - < Item Track Balance Checking >
  - < Track Balance Additions / Divide by Number of People >

- B. Amount Track System (optional memory board required)**

- < Opening an Amount Track >
- < Closing an Amount Track Temporarily >
- < Picking Up an Amount Track >
- < Closing an Amount Track Finally >
- < Amount Track Card >
- < Amount Track Transfer >

## A. Item Track System

### a) Opening a New Track & Closing Temporarily

#### < Opening a New Item Track >

When **Automatic Item Track Number Method** has been programmed by [SF-15.a=0], simply press **ITEM TRACK #** key to open a new track.

**ITEM TRK#** --- new Item Track number is automatically assigned

When **Manual Track Number Method** has been programmed by [SF-15.a=1], enter a random 1 ~ 7 digit track number and press **ITEM TRACK #** key.

enter track # --- **ITEM TRK#** --- new Item Track number is assigned

A track number may be assigned at anytime while in a transaction.

#### < Closing an Item Track Temporarily >

Enter registrations as normal and then, it can be closed temporarily through **NB** (New Balance) key.

Automatic Item Track Number Method		RECEIPT	
KEY ENTRY	DISPLAY	<.....1>	0.00
ITEM TRACK #	NEW TRACK < 1> is displayed on the top.	SALMON STEAK	11.00
SALMON STEAK		BEER	2.50
BEER		Today chag	13.50
NB		<b>N . B</b>	<b>1 3 . 5 0</b>
		QUANTITY	2
		#001-000001	19:13R
		CLERK NAME 00001	

current charge (key/symbol #54) printed by [SF-15.d]

When Manual Track Number Method is used, enter the track number first, then press **ITEM TRACK #** key to assign a new track.

< Issuing a Post-Bill and/or Subtotal Bill >

Immediately after a track is closed temporarily and **CHECK-OUT BILL** key is pressed, a Subtotal Bill which shows the track contents is printed. If **BUFFER PRINT** key is pressed, a Post-Bill which shows only the last track's contents is printed. After the subtotal bill issue, post-bill can not be printed.

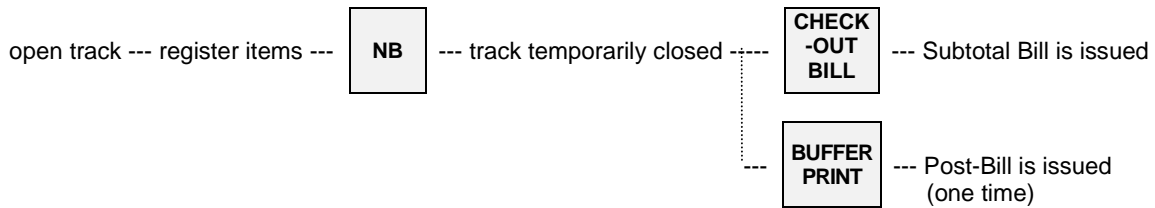

After a Post-Bill is issued, a Subtotal Bill can be still issued by entering the track number and pressing the **CHECK-OUT BILL** key.



**Post-Bill** (See Sample 1 in the next page.)

Post-Bill shows the last transaction's contents on a receipt in the receipt-off condition or on a slip if programmed to use.

\* **Automatic Line Finder (Slip Printer TP-620)**

If a Post-Bill of the track has been issued previously, the automatic line finder advances the Post-Bill past the previously-printed area, and prints only the last transaction's contents as a continuation of the previous Post-Bill. Then it is issued each time when the track is closed, the Post-Bill can be used as a Check-Out Bill.

However, Item Track System has a Check-Out Bill function so that Post-Bill is not be used as a Check-Out Bill normally.

**Subtotal Bill** (See Sample 2 in the next page.)

Subtotal Bill shows the temporarily closed track's contents on a receipt or on a slip if programmed to use. If the slip printer is not programmed to use, an entire subtotal bill is always issued on a receipt.

\* **Subtotal Bill Format for Slip Printer TP-620 --- available when the slip printer is used [SF-83.h=1]**

Depending on programming [SF-83.a,b], a Subtotal Bill is issued by one of two methods;

- i) Always entire Subtotal Bill is printed on new slip.
- ii) Additional transactions are printed as a continuation of the previous Subtotal Bill.

This method is used to have a Check-Out Bill by issuing the Subtotal Bills.

\* **Subtotal Bill Printed on Receipt**

Even if a slip printer is programmed to use, it is possible to print it on a receipt by **SLIP OFF** key depression. In this case, after **SLIP OFF** key depression, enter the track number and press **CHECK-OUT BILL** key.

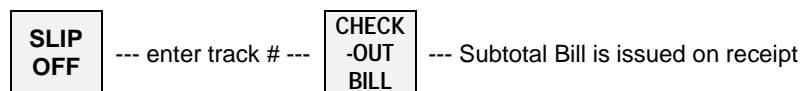

**Sample 1 Post-Bill --- available immediately after the track is closed**

KEY ENTRY	POST-BILL (SLIP)	
BUFFER PRINT 1	< . . . . . 1 > Served by CLERK NAME 00001	
	SALMON STEAK 11.00	
	BEER 2.50	
	Today chag 13.50	
	<b>N . B</b> 13.50	current charge (key/symbol #54)
	QUANTITY 2	printed by [SF-15.d]
	JUL17/2003#001-000001 19:13R CLERK NAME 00001	

If the "tax is calculated each time the track is closed by either **NB** key or a media key" is programmed by [SF-16.g], then **BUFFER PRINT 1** key prints a post-bill with VAT data, **BUFFER PRINT 2** key prints a post-bill without VAT data.

**Sample 2 Subtotal Bill**

Depends on programming [SF-83.a,b], it is issued one of two methods for slip printer TP-620.

**i) Always entire Subtotal Bill is printed on new slip** --- any time can be issued [SF-83.a,b=00]

KEY ENTRY	SUBTOTAL BILL (SLIP)	
1	< . . . . . 1 > Served by CLERK NAME 00001	
CHECK-OUT BILL 1	SALMON STEAK 11.00	
	BEER 2.50	
	<b>SBTL</b> 13.50	
	QUANTITY 2	Current charge is not printed on
	JUL17/2003#001-000001 19:13R CLERK NAME 00001	Subtotal/Check-out bill.

- If "tax calculated temporarily and printed on subtotal bill (not for post-bill)" is programmed by [SF-16.f], temporarily calculated tax amounts are printed.
- If the "tax is calculated each time the track is closed by either **NB** key or a media key" is programmed by [SF-16.g], then **CHECK-OUT BILL 1** key prints a subtotal bill with VAT data, **CHECK-OUT BILL 2** key prints a subtotal bill without VAT data.

**ii) Additional transactions are printed as a continuation of the previous Subtotal Bill** [SF-83.a,b=11]

By this method, Subtotal Bill can only be issued **one time** for each transaction. If additional items are registered but a Subtotal Bill need not be issued, the contents will be stored in memory.

<b>Item track # 1 is picked up and additional items are registered.</b>		
KEY ENTRY	SUBTOTAL BILL (SLIP TP-620)	
1 ITEM TRACK #	< . . . . . 1 > Served by CLERK NAME 00001	
SALMON STEAK	SALMON STEAK 11.00	
BEER	BEER 2.50	
NB	<b>SBTL</b> 13.50	
	QUANTITY 2	
	JUL17/2003#001-000001 19:13R CLERK NAME 00001	
CHECK-OUT BILL 1	< . . . . . 1 > Served by CLERK NAME 00001	
	SALMON STEAK 11.00	
	BEER 2.50	
	<b>SBTL</b> 27.00	
	QUANTITY 4	
	JUL17/2003#001-000002 19:30R CLERK NAME 00001	

## b) Picking Up a Track & Closing a Track Finally

### < Picking Up an Item Track >

To pick up a track, enter the Item Track Number and press **ITEM TRACK #** key.

enter track # ---  --- previous balance with track # is displayed

### < Closing an Item Track Finally >

Enter registrations as normal and then it can be closed finally through one of a **Media** (Total) keys.

open track --- register items ---  --- Item Track is finally closed  
Check-Out bill must be issued by **CHECK-OUT BILL** key.

### < Issuing a Check-Out Bill >

Depending on programming [SF-83.a,b], a Check-Out Bill is issued on a slip printer TP-620 by one of three methods (see Samples on the next pages). However, if no Subtotal Bill has been issued, the entire Check-Out Bill is always printed, regardless of programming.

- i) Always **entire Check-Out Bill** is printed on new slip. [SF-83.a,b=00]
- ii) If only a closing operation is done since the last Subtotal Bill issue, **only the closing line is printed as a continuation of the Subtotal Bill**. If additional registrations have been done, **entire Check-Out Bill** is printed on new slip. [SF-83.a,b=01]
- iii) Additional registrations are always printed as a continuation of the previous Subtotal Bill. [SF-83.a,b=11]

#### \* Check-Out Bill Keys

**CHECK-OUT BILL 1:** Prints a check-out bill with VAT data on slip or receipt

**CHECK-OUT BILL 2:** Prints a check-out bill without VAT data on slip or receipt

**CHECK-OUT BILL 3:** Prints a check-out bill with VAT data on slip or receipt (thermal printer only)

If "without slip printer" has been set, the check-out bill on receipt will have German Declaration Form for the law of German restaurant.

#### \* Check-Out Bill Issue Cancellation

If a check-out bill issue is not necessary, it can be skipped by a **BILL CANCEL** key depression.

In order to stop the check-out bill issue, you can select "without check-out bill issue" [SF-16.h].

media closing --- 

#### \* Check-Out Bill Printed on Receipt

Even if a slip printer is programmed to use, it is possible to print it on a receipt by **SLIP OFF** key depression.

 ---  --- Check-Out Bill is issued on receipt

**i) Always entire Check-Out Bill is printed on new slip. [SF-83.a,b=00]**

KEY ENTRY	RECEIPT	
1	<.....1>	27.00
ITEM TRACK #	TEA	3.00
	COFFEE	2.50
	Today chag	5.50
TEA	CASH	32.50
COFFEE	QUANTITY	2
CASH	#001-000003	20:30R
	CLERK NAME 00001	
	CHECK-OUT BILL (SLIP TP-620)	
CHECK-OUT BILL 1	CHECK OUT BILL	Check-out bill header printed by [SF-6.b].
	<.....1>	
	Served by CLERK NAME 00001	
	2 X 11.00 SALMON STEAK	22.00
	2 X 2.50 BEER	5.00
	TEA	3.00
	COFFEE	2.50
	CASH	32.50
	QUANTITY	6
	JUL17/2003#001-000003 20:30R CLERK NAME 00001	Items are consolidated by [SF-67.h=0].
		Current charge is not printed on Subtotal/Check-out bill.

**ii) When a final closing operation is done since the last Subtotal Bill issue, a closing line only is printed on the last Subtotal Bill. [SF-83.a,b=01]**

If additional registrations have been done, entire Check-Out Bill is printed on new slip.

The automatic line finder advances the slip paper past the previously-printed area and prints only the closing lines (the check-out bill header if programmed, media amount and tax data, etc.) on the bill.

KEY ENTRY	CHECK-OUT BILL (SLIP TP-620)	
1 ITEM TRACK #	<.....1>	
CASH	Served by CLERK NAME 00001	
	2 X 11.00 SALMON STEAK	22.00
	2 X 2.50 BEER	5.00
	QUANTITY	4
CHECK-OUT BILL 1	JUL17/2003#001-000002 19:30R CLERK NAME 00001	Check-out bill header printed by [SF-6.b].
	CHECK OUT BILL	
	<.....1>	
	Served by CLERK NAME 00001	
	CASH	27.00
	QUANTITY	4
	JUL17/2003#001-000003 21:30R CLERK NAME 00001	

If a Subtotal Bill has not been issued previously, **entire Check-Out Bill** is always issued.

iii) Additional registrations are always printed as a continuation of the previous Subtotal Bill.  
 [SF-83.a,b=11]

KEY ENTRY	RECEIPT
1 ITEM TRACK #	<.....1> 27.00
TEA	TEA 3.00
COFFEE	COFFEE 2.50
CASH	Today chag 5.50
	CASH 32.50
	QUANTITY 2
	#001-000003 20:30R
	CLERK NAME 00001
	CHECK-OUT BILL (SLIP TP-620)
	<.....1>
	Served by CLERK NAME 00001
	SALMON STEAK 11.00
	BEER 2.50
	SBTL 13.50
	QUANTITY 2
	JUL17/2003#001-000001 19:13R CLERK NAME 00001
	<.....1>
	Served by CLERK NAME 00001
	SALMON STEAK 11.00
	BEER 2.50
	SBTL 27.00
	QUANTITY 4
	JUL17/2003#001-000002 19:30R CLERK NAME 00001
CHECK-OUT BILL 1	CHECK OUT BILL
	<.....1>
	Served by CLERK NAME 00001
	TEA 3.00
	COFFEE 2.50
	CASH 32.50
	QUANTITY 6
	JUL17/2003#001-000003 20:30R CLERK NAME 00001

Check-out bill header printed by [SF-6.b].

If a Subtotal Bill has not been issued previously, **entire Check-Out Bill** is always issued.

### c) Table # Assigned to an Item Track

Table number assignment (random 1 ~ 4 digit) and pick up are available as follows:

Automatic Item Track # Method [SF-15.a=0]	Table assignment: available [SF-12.a=0 or 1] Pick-up by Table number: available under <b>non</b> -clerk interrupt system [SF-12.a=0]
Manual Item Track # Method [SF-15.a=1]	Table assignment: available under clerk interrupt system [SF-12.a=1] Pick-up by Table number: <b>not</b> available

#### < Assigning a Table Number to an Item Track >

Table #5 assigned to an Item Track (Automatic Track Number Method)	
KEY ENTRY	RECEIPT
ITEM TRACK #	<.....10> 0.00
5 TABLE #	* . . . 5 *
1 PERSON	ROAST BEEF 12.00
ROAST BEEF	RED WINE 3.00
RED WINE	N . B 15.00
NB	PERSN 1
	#001-000020 19:30R
	CLERK NAME 00001

track number  
table number (always printed in double-width and centered)  
number of people

\* Table number \* is printed in double-width with < track number > on the kitchen printer as follows:

KITCHEN PRINTER 1 AT KITCHEN	KITCHEN PRINTER 2 AT BAR
ECR NO.1 --> KITCHEN * . . . 5 * <.....10> CLERK NAME 00001	ECR NO.2 --> BAR * . . . 5 * <.....10> CLERK NAME 00001
1 ROAST BEEF	1 RED WINE
JUL20/2003#001-000020 19:30	JUL20/2003#001-000020 19:30

When using "Manual Track Number Method" (under Clerk Interrupt System.)	
ECR NO.1 --> KITCHEN <1234567> *...5* CLERK NAME 00001	< manual track number > is printed in double-width and * table number * is printed in normal size
1 T-BONE STEAK	Table # can be assigned only under the clerk interrupt system for Manual Track Number Method.
JUL21/2003#001-000005 19:35	

#### < Assigning a Table Number to a Multiple Number of Tracks >

The same table number can be assigned to a number of tracks. Open each track and assign a table number by using **TABLE #** key. This operation is useful when different groups of customers sit at the same table.

**< Picking Up an Item Track by Table Number >**

Item Track can be picked up by either the track number or assigned table number for Automatic Item Track # Method only. Under the clerk interrupt system, the track pick-up by the assigned table number is **not** available.

Automatic Item Track # Method [SF-15.a=0]	Pick-up by Table number: available under <b>non</b> -clerk interrupt system [SF-12.a=0]
Manual Item Track # Method [SF-15.a=1]	Pick-up by Table number: <b>not</b> available

Tracks having same assigned table number can be picked up by the same table number.

- 1) Enter the table number and press **TABLE #** key. The track list which have the same table number appears. The track is not opened until **ITEM TRACK #** key is pressed. If the table is assigned to only one track, the track will be opened automatically.
- 2) By pressing **TABLE #** key again, the second track is selected. Press **TABLE #** key until the required track is selected.
- 3) Press **ITEM TRACK #** key to open the track.

**d) Track Transfer to a New Track or a Designated Track [SF-15.b=1]**

Track transfer is done by using **NB** key and **CASH/TTL 25** key if permitted by [SF-15.b=1].

Transfer can be canceled by pressing **CL** key at any time instead of **CASH/TTL 25** key.

When the clerk track assignment system is used, only the assigned clerk or manager clerk can transfer his/her own track to other track assigned to him/her.

**From a Designated Track to a New Track**

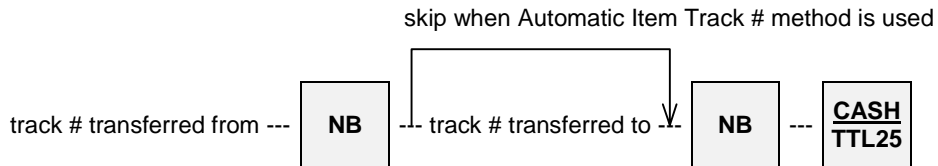

Track #10 is transferred to Track #15 (Manual Item Track # Method)		
KEY ENTRY	DISPLAY (on the top)	CONFIRMATION RECEIPT
10 NB	TRACK TRANSFER	<.....10> -> <.....15>
15 NB	ARE YOU SURE ?	#001-000023 09:10R
CASH/TTL 25		CLERK NAME 00001
		Track #10 will be free and Track #15 is temporarily memorized as New Balance.

### e) Item Transfer to Item Track in Scroll Display Mode

Items in a transaction or in Item Track can be transferred to a new track or a specified track in the scroll display mode.

Keys used for Item Transfer	
<b>SCROLL, PAGE UP/DOWN</b>	leads you into the scroll display mode
<b>[ • ]</b>	select/cancel transfer items
<b>ITEM TRANSFER</b>	enter into/exit from item transfer mode
<b>CASH/TTL 25</b>	execute item transfer exit from the scroll display mode [SF-117.a=0]
<b>ENTER</b>	exit from the scroll display mode

#### < Item Transfer Sequence >

1. Enter into the scroll display mode by pressing **SCROLL, PAGE UP/DOWN** key **during a transaction**.
2. Select items that you wish to transmit to other track by pressing [ • ] key.  
To split the multiplied PLUs for transfer, enter the number of quantity you like to transfer and press **X2** and [ • ] keys. Multiplied PLUs entered by X2 key can be split to be transferred. PLUs multiplied not by X2 key can be split only under "PLU consolidated" [SF-67.h=0] (can not be split under "PLU not consolidated" [SF-67.h=1]).  
**To cancel an item** among the selected items, press [ • ] key again on the item selected.  
**To cancel all the items** selected, press **CASH/TTL 25** or **ENTER** key and exit from the scroll display mode.
3. Enter into the "Item Transfer Mode" by pressing **ITEM TRANSFER** key.
4. Enter the track number and press **ITEM TRACK #** key, or press **ITEM TRACK #** key directly for a new track in the Automatic Item Track # Method.
5. If required, enter a table number by using ten-key and **TABLE #** key.
6. Press **CASH/TTL 25** key to transfer the item.  
You can exit the "Item Transfer Mode" by pressing **ITEM TRANSFER** key instead of **CASH/TTL 25**. It does **not** cancel all selections for the item transfer.
7. You can repeat operations from the above step 2 to select items here. Such other scroll display functions as scroll void are available also.
8. Press **CASH/TTL 25** or **ENTER** key ([SF-117.a]) again to exit the scroll display mode and continue registration.

Transferred items are memorized in the assigned track with the table number (if entered) and the track is temporarily closed as New Balance.

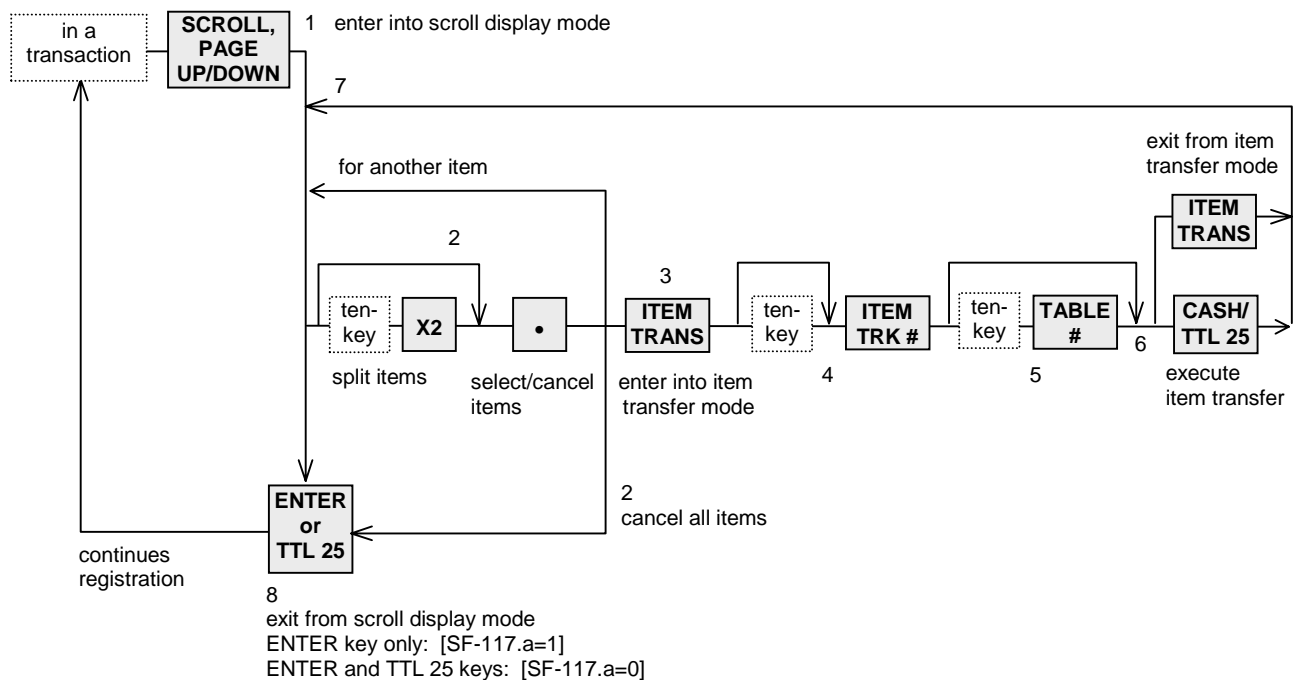

Item transfer to a new Item Track (Manual Track # Method):  
 White Wine and Salmon Steak are transferred to Track #12.

KEY ENTRY	KEY EXPLANATION
BEER	
WHITE WINE	
SALMON STEAK	
SCROLL, PAGE UP/DOWN	(1) enters into Scroll Display Mode
[•]	(2) selects item to be transferred "ITEM TRANS." is displayed on the item to be transferred.
SCROLL UP	(3) moves cursor to the 2nd item
[•]	(4) selects item to be transferred
ITEM TRANSFER	(5) enters into Item Transfer Mode
12 ITEM TRACK #	(6) enters Item Track #
CASH/TTL 25	(7) executes Item Transfer
ENTER (or TTL 25)	(8) exits from Scroll Display Mode
CASH	(9) closes the transaction by cash

RECEIPT	
BEER	2.50
WHITE WINE	5.00
SALMON STEAK	11.00
WHITE WINE	5.00
↑↑↑↑↑↑↑↑↑↑ ITEM TRNS.↑↑↑↑↑↑↑↑↑↑	
SALMON STEAK	11.00
↑↑↑↑↑↑↑↑↑↑ ITEM TRNS.↑↑↑↑↑↑↑↑↑↑	
CASH	2.50
QUANTITY	1
#001-000030	20:20R
CLERK NAME 00001	

KITCHEN PRINTER 1  
 AT KITCHEN

```

  ECR NO.1 --> KITCHEN
  <.....12>      CLERK NAME 00001

  1  SALMON STEAK

  JUL17/2003#001-000030 20:20
  
```

Transferred items are printed on the kitchen printer having the assigned track numbers with the same last line as the original transaction.

KITCHEN PRINTER 2  
 AT BAR

```

  ECR NO.2 --> BAR
  <.....12>      CLERK NAME 00001

  1  BEER

  JUL17/2003#001-000030 20:20
  -----
  ECR NO.2 --> BAR
  <.....12>      CLERK NAME 00001

  1  WHITE WINE

  JUL17/2003#001-000030 20:20
  
```

Transferred items are memorized in the assigned track with the table number (if entered) and the track is temporarily closed as New Balance.

Multiplied PLUs can be split to be transferred. Enter number of the quantity you would like to split transfer and press **X2** and [ • ] keys.

Item transfer to a new Item Track (Manual Track # Method):		
1 Beer transferred to Track #12.		
KEY ENTRY	KEY EXPLANATION	RECEIPT
2 [X2] BEER		2 X 2.50 BEER 2.50
3 [X2] WHITE WINE		3 X 5.00 WHITE WINE 15.00
SALMON STEAK		SALMON STEAK 11.00
SCROLL, PAGE UP/DOWN	(1) enters into Scroll Display Mode	BEER 2.50
SCROLL UP, SCROLL UP	(2) moves cursor to "2 X BEER"	↑↑↑↑↑↑↑↑↑↑ ITEM TRNS.↑↑↑↑↑↑↑↑↑↑
1 [X2] [•]	(3) enters number of quantity you like to split (quantity of item transferred pops up)	<b>CASH</b> 28.50
ITEM TRANSFER	(4) enters into Item Transfer Mode	Receipt format differs if [SF-4.h=1].
12 ITEM TRACK #	(5) enters Item Track #	
CASH/TTL 25	(6) executes Item Transfer	
ENTER (or TTL 25)	(7) exits from Scroll Display Mode	
CASH	(8) closes the transaction by cash	

< Notes on Item Transfer >

If a PLU has been registered with the following items, all these additional entries on the PLU are also selected automatically;

- link PLU
- simple condiment PLU
- cooking message
- plus / discount amount on item
- % on item

If the following operations have been done in a transaction, the item transfer can not be done;

- plus / discount amount on subtotal
- % on subtotal
- adjustment
- manual tax entry
- tax exemption
- tendering amount entry

If "tax calculated each time on New Balance closing" [SF-16.g=1] has been set, the items in the temporarily closed track can not be transferred.

If **KP DATA SEND** key is pressed after the items are transferred to an Item Track, only the not-transferred items in the transaction are sent to the kitchen printer. The items transferred to the Item Track are sent to the kitchen printer immediately after the transaction is closed.

PLUs multiplied not by X2 key can be split for item transfer only under "PLU consolidated" [SF-67.h=0] (can not be split under "PLU not consolidated" [SF-67.h=1]).

Items transferred by split item transfer are not printed on kitchen printer in case they are already printed on kitchen printer.

**f) Item Track Transfer to Amount Track (optional memory board required)**

The payable amount of money on the Item Track currently under use can be charged on the Amount Track if permitted by programming [SF-15.b=1]. This function is useful for frequent restaurant customers.

The customer's due amount tracked on the Item Track can be transferred to the Amount Track by following the operation sequence below;

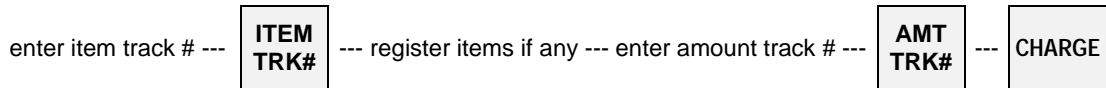

After the amount of Item Track is transferred to the specified Amount Track by **CHARGE** key, the Check-Out Bill of the Item Track must be issued by pressing **CHECK-OUT BILL** key.

Track #10 is transferred to Track #15 (Manual Item Track # Method)	
KEY ENTRY	RECEIPT
12 ITEM TRACK #	<.....12> 16.00
TEA	* . . . 5 *
COFFEE	TEA 3.00
150 AMOUNT TRACK #	COFFEE 2.50
CHARGE	<<.....150>> 0.00
	Today chag 5.50
	CHARGE 21.50
	QUANTITY 2
	#001-000035 21:30R
	CLERK NAME 00001
CHECK-OUT BILL 1	CHECK-OUT BILL (SLIP)
	CHECK OUT BILL
	<.....12> * . . . 5 *
	Served by CLERK NAME 00001
	WHITE WINE 5.00
	SALMON STEAK 11.00
	TEA 3.00
	COFFEE 2.50
	<<.....150>> 0.00
	CHARGE 21.50
	QUANTITY 4
	JUL20/2003#001-000035 21:30R CLERK NAME 00001

### g) Item Track Balance Calculation (display only)

#### < Item Track Balance Checking >

This function is used to check a track balance on the display.

Press **BALANCE CALCULATION** key and enter the item track number as follows:

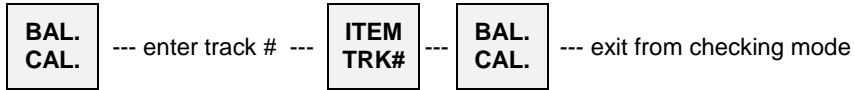

\* BAL-CAL MODE \* is displayed on the top.

#### < Track Balance Additions / Divide by Number of People >

Also a track's subtotal can be displayed and other track's subtotal may be added with the total being displayed. It is then possible to divide by the number of people. Tracks are not consolidated.

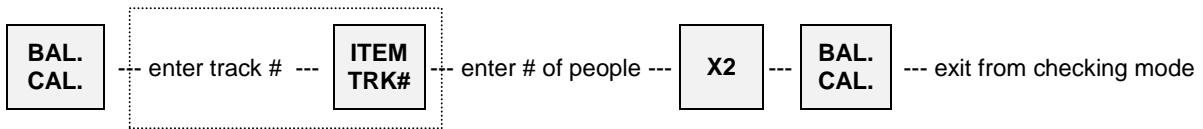

Repeat this step to add other track balance.

Total balance is divided by number of people and the result is displayed.

**B. Amount Track System (optional memory board required)**

This system records transaction totals only. The registered items per track can not be recorded.

**< Opening an Amount Track >**

Enter a random 1 ~ 7 digit track number and press **AMOUNT TRACK #** key.  
A track number may be assigned at anytime during a transaction.

enter track # --- 

<b>AMT TRK#</b>
---------------------

 --- entered Amount Track number is assigned

**< Closing an Amount Track Temporarily >**

Enter registrations as normal and then it can be closed temporarily through **CHARGE** key.

open track --- register items --- 

<b>CHARGE</b>
---------------

 --- Amount Track is temporarily closed  
Post-Bill can be issued if required by **BUFFER PRINT** key

**< Picking Up an Amount Track >**

To pick up a track, enter the Amount Track Number and press **AMOUNT TRACK #** key.

enter track # --- 

<b>AMT TRK#</b>
---------------------

 --- previous balance with track # is displayed

**< Closing an Amount Track Finally >**

Enter registrations as normal and then it can be closed finally through one of a Media (Total) keys.

open track --- register items --- 

<b>TTL</b>
------------

 --- Amount Track is finally closed  
Post-Bill can be issued if required by **BUFFER PRINT** key

<p>KEY ENTRY 1234567 AMOUNT TRACK # SALMON STEAK BEER CHARGE  BUFFER PRINT 1 for post-bill --- see next page *1</p>	<table border="1" style="width: 100%; border-collapse: collapse;"> <tr><td colspan="2" style="text-align: center;">RECEIPT</td></tr> <tr><td>&lt;&lt;1234567&gt;&gt;</td><td style="text-align: right;">0.00</td></tr> <tr><td>SALMON STEAK</td><td style="text-align: right;">11.00</td></tr> <tr><td>BEER</td><td style="text-align: right;">2.50</td></tr> <tr><td>Today chag</td><td style="text-align: right;">13.50</td></tr> <tr><td>CHARGE</td><td style="text-align: right;">13.50</td></tr> <tr><td style="text-align: center;">QUANTITY</td><td style="text-align: right;">2</td></tr> <tr><td>#001-000002</td><td style="text-align: right;">19:14R</td></tr> <tr><td style="text-align: center;">CLERK NAME</td><td style="text-align: right;">00001</td></tr> </table>	RECEIPT		<<1234567>>	0.00	SALMON STEAK	11.00	BEER	2.50	Today chag	13.50	CHARGE	13.50	QUANTITY	2	#001-000002	19:14R	CLERK NAME	00001	<p>current charge (key/symbol #54) printed by [SF-15.d]</p>
RECEIPT																				
<<1234567>>	0.00																			
SALMON STEAK	11.00																			
BEER	2.50																			
Today chag	13.50																			
CHARGE	13.50																			
QUANTITY	2																			
#001-000002	19:14R																			
CLERK NAME	00001																			
<p>1234567 AMOUNT TRACK # CAKE COFFEE CASH  BUFFER PRINT 1 for post-bill --- see next page *2</p>	<table border="1" style="width: 100%; border-collapse: collapse;"> <tr><td>&lt;&lt;1234567&gt;&gt;</td><td style="text-align: right;">13.50</td></tr> <tr><td>CAKE</td><td style="text-align: right;">1.50</td></tr> <tr><td>COFFEE</td><td style="text-align: right;">1.50</td></tr> <tr><td>Today chag</td><td style="text-align: right;">3.00</td></tr> <tr><td>CASH</td><td style="text-align: right;">16.50</td></tr> <tr><td style="text-align: center;">QUANTITY</td><td style="text-align: right;">2</td></tr> <tr><td>#001-000016</td><td style="text-align: right;">20:14R</td></tr> <tr><td style="text-align: center;">CLERK NAME</td><td style="text-align: right;">00001</td></tr> </table>	<<1234567>>	13.50	CAKE	1.50	COFFEE	1.50	Today chag	3.00	CASH	16.50	QUANTITY	2	#001-000016	20:14R	CLERK NAME	00001	<p>Tax always calculated by CHARGE and media closing.</p>		
<<1234567>>	13.50																			
CAKE	1.50																			
COFFEE	1.50																			
Today chag	3.00																			
CASH	16.50																			
QUANTITY	2																			
#001-000016	20:14R																			
CLERK NAME	00001																			

### Post-Bill --- shows the last transaction's contents

Immediately after temporarily closing a track transaction and either **BUFFER PRINT 1** or **2** key is pressed, a post-bill is issued on a receipt in the receipt-off condition or on a slip if programmed to use.

If a Post-Bill of the track was issued previously, the automatic line finder advances the Post-Bill past the previously-printed area, and prints only the last transaction's contents as a continuation of the previous Post-Bill.

So the Post-Bill can be used instead of the Check-Out Bill for the Item Track System which is not available for the Amount Track System.

```
POST-BILL (SLIP)
<<1234567>>
  Served by CLERK NAME 00001
SALMON STEAK                11.00
BEER                        2.50
          Today chag        13.50
CHARGE                    13.50
          QUANTITY          2
JUL25/2003#001-000002 19:14R CLERK NAME 00001
<<1234567>>
  Served by CLERK NAME 00001
CAKE                        1.50
COFFEE                      1.50
          Today chag        3.00
CASH                      16.50
          QUANTITY          2
JUL28/2003#001-000016 20:14R CLERK NAME 00001
```

Tax is always calculated each time the track is closed by either **CHARGE** key or a media key.  
**BUFFER PRINT 1** key prints a post-bill with VAT data, **BUFFER PRINT 2** key prints a post-bill without VAT data.

Even if a slip printer is programmed to use, it is possible to print it on a receipt by **SLIP OFF** key depression.

### < Amount Track Card >

If an optional card reader is fitted and Amount Track Cards have been prepared by a card writer, an Amount Track is picked up by swiping the card at the beginning of a transaction.

After the Amount Track is picked up, the track is automatically closed by **CHARGE** key by swiping the card again. 4-digit store code (S#-xxxx) and 7-digit amount track number (C#-0xxxxxxx) are printed before the last line.

< **Amount Track Transfer [SF-15.b=1]** >

Track transfer is done by using **CHARGE** key and **CASH/TTL 25** key if permitted by [SF-15.b=1].

Transfer can be canceled by pressing **CL** key at any time before **CASH/TTL 25** key is pressed.

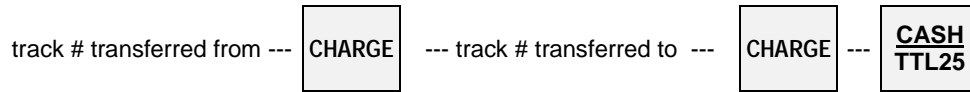

Track #4 is transferred to Track #5		
KEY ENTRY	DISPLAY (on the top)	CONFIRMATION RECEIPT
4 CHARGE	TRACK TRANSFER	<div style="border: 1px solid black; padding: 5px;">                     &lt;&lt;.....4&gt;&gt;-&gt;&lt;&lt;.....5&gt;&gt;                      #001-000022 09:00R                      CLERK NAME 00001                 </div>
5 CHARGE	ARE YOU SURE ?	
CASH/TTL 25		Track #4 will be free and Track #5 is temporarily memorized as CHARGE.

### ***30. Floating Item Track / Floating Amount Track***

Almost all operations are same as the normal Item Track and Amount Track operations. The only difference is that the track data is floating among ECRs in the IRC system. In order to use this system, the IRC status check must have been performed with each ECR.

The following describes the key sequences and memory conditions on the master which picks up the track and the slave ECRs;

#### **< New Item / Amount Track Open >**

Track Number Entry Method, either Manual Track Number Method or Automatic Item Track Number Method, used on the ECRs should be the same in the IRC system.

##### **Manual Track Number Method**

- When the track number is entered with **ITEM TRACK #** or **AMOUNT TRACK #** key, the master checks the track memories in the IRC system.
- If it is a new track number in the IRC system, the track number is opened.
- If it is already used, the master picks up the track data.

##### **Automatic Item Track Number Method (Item Track System Only)**

- When **ITEM TRACK #** key is pressed, the master searches the slaves for the track number next to the track number on the master. When the unique automatic track number method is used, the track number will be the next to track number on each ECR.
- If it is a new track number in the IRC system, the track number is opened.
- If it is already used by other ECR, the master searches the slaves for the next track number until a new track number is found within the programmed maximum track number. When the unique automatic track number method is used, it will be the next track number on each ECR.
- If there is no new track number, the master checks the already closed track having the smallest number and it will be opened as a new track.
- If there is no closed track, the master displays Warning Message #34.

#### **< Item / Amount Track Pick Up >**

When the track number is entered with **ITEM TRACK #** or **AMOUNT TRACK #** key, the master searches the track memory by itself. If the track is not found on the master, the master then searches the slaves and collects the track data from it. The collected data is deleted from the slave.

If a communication error occurs, the master makes "New Track" by pressing **X2** key if permitted by [SF-17.d,g]. The track made by **X2** key should be closed by **NB** key or **CHARGE** key, then the "track consolidation" (see next page) must be performed to avoid the tracks having same number on the master and slave.

**< Item / Amount Track Consolidation >**

This is used to consolidate the tracks in the IRC system having same track number made by pressing **X2** key on the master while the same track is used by other ECR or they are busy.

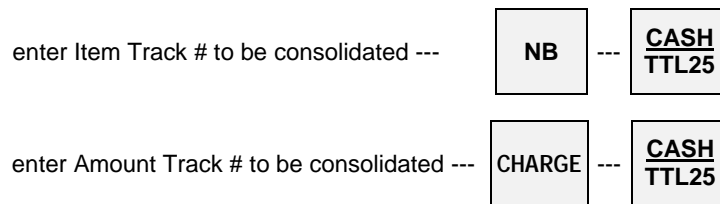

The master searches the slaves and collects all tracks having same track number. The master consolidates the tracks into a track and the collected tracks on the slaves are deleted.

Amount track #10 is collected	
KEY ENTRY	CONFIRMATION RECEIPT
10 CHARGE	<<.....10>>-><<.....10>>
CASH/TTL 25	#001-000025 09:20R
	CLERK NAME 00001

**< Subtotal Bill Issue > --- Item Track System Only**

If the master does not have this, it searches the slaves and issues a subtotal bill by referring to the track data on the slave. The track data is still on the slave.

**< Check-Out Bill Issue > --- Item Track System Only**

This can be issued by the master only.

**< Table # Assignment / Pick-Up > --- Item Track System Only**

Table number assignment is possible when Automatic Item Track Number Method is used. Under the clerk interrupt system, it is possible when either Automatic or Manual Track Number Method is used. Item Track pick-up by the assigned table number is possible on the master, but it does **not** pick up the tracks in the slaves. Under the clerk interrupt system, the track pick-up by the table number is **not** possible.

**< Item Track Transfer to a New Item Track >**

If source track does not exist on the master, the master searches the slaves and collects the track data from the slave. The collected data is deleted from the slave. Then new track is made on the master and the source track is transferred to new track. Finally the master deletes the source track.

**< Item Track Transfer to a Designated Item Track >  
< Amount Track Transfer to a Designated Amount Track >**

If source track and/or the designated track do not exist on the master, the master searches the slaves and collects the track data from the slave. The collected data is deleted from the slave. Then the source track is transferred to the designated track. Finally, the master deletes the source track.

### < Item Track Transfer to Amount Track >

If source Item Track and/or the objective Amount Track do not exist on the master, the master searches the slaves and collects the track data from the slave. The collected data is deleted from the slave. Then the Item Track is transferred to the Amount Track. After the Check-Out Bill is issued, the master deletes the source Item Track.

### < Item Track Balance Checking >

If this does not exist on the master, the master searches the slaves and collects the track data from the slave. The collected data is deleted from the slave. Then the master shows the track balance.

### < Item Track Additions >

If the entered tracks do not exist on the master, the master searches the slaves and collects the track data from the slave. The collected data is deleted from the slave. Then the master adds the tracks, but does not consolidate them.

### < Notes for Communication Error >

If a communication error occurs, one of "-- IRC BUSY --", "ECR#-xxx ERROR" or "ECR#-xxx BUSY" (xxx = ECR machine number) is displayed, then;

- retry the communication by pressing **CASH/TTL 25** key, or
- cancel the communication by pressing **CL** key, or
- make "New Track" by **X2** key (if permitted by [SF-17.d.g]).

Item Track made by **X2** key should be closed by **NB** key and Amount Track made by **X2** key should be closed by **CHARGE** key, then the **track consolidation** must be performed to avoid the tracks having same number on the master and slave.

When **CL** key is pressed, depending on the cases, the master displays REQ . Z62-xxx or REQ . X62-xxx with Item Track number and REQ . Z66-xxx or REQ . X66-xxx with Amount Track number and prints the message on the journal.

When **REQ . Z62 ( 66 ) -xxx** is displayed,

(This is displayed when the master collects the track data from the slave, but the slave does not delete it yet.)

1. Press **CL** key again to clear the error.
2. Then enter the track number with **ITEM (AMOUNT) TRACK #** key again to continue the track operation.
3. After the track operation is completed, take **Z-62 (66) individual Item (Amount) Track report on the ECR machine number xxx** to delete the track data from that ECR to avoid the tracks having same number on the master and slave.

When **REQ . X62 ( 66 ) -xxx** is displayed,

(This is displayed when the master collects the track data from the slave and the slave deletes it but the confirmation of such deletion is not sent to the master yet.)

1. Press **CL** key again to clear the error condition.
2. Then enter the track number with **ITEM (AMOUNT) TRACK #** key again to continue the track operation.
3. After the track operation is completed, take **X-62 (66) individual Item (Amount) Track report on the ECR machine number xxx** in order to make sure that the track is deleted from the slave.

### 31. Previous Balance Plus (PB+) / Previous Balance Minus (PB-)

The PB+ for charge and PB- for deposit can be used in place of track operations when the track memory is full. These operations are similar to track operations in that they allow for intermittent registrations however no track numbers are used. In other words, the ECR does not retain data on individual items registered. Also, the automatic line finder on the slip printer is inoperative, however, the manual line finder can be used.

KEY ENTRY	DISPLAY (popped up)	RECEIPT	
5 MESSAGE		CUSTOMER	5#
PB+	PB.P 0.00	PB.P	0.00
BANANA CAKE		BANANA CAKE	1.25
TEA		TEA	0.80
NB		Today chag	2.05
		N.B	2.05
		QUANTITY	2
		#001-000024	15:42R
		CLERK NAME	00001
BUFFER PRINT 1 --- post-bill is printed on the slip (see below * 1)			
5 MESSAGE		CUSTOMER	5#
205 PB+	PB.P 2.05	PB.P	2.05
ICE CREAM		ICE CREAM	2.00
CASH		Today chag	2.00
		CASH	4.05
		QUANTITY	1
		#001-000025	15:55R
		CLERK NAME	00001

The balance must be entered before pressing **PB+ / PB-** keys.

#### < Manual Line Finder Operation (TP-620) >

Input the line number from where printing should start and press **BUFFER PRINT** key. The input line number should not be more than the preprogrammed maximum number of lines on the slip. Bills which are issued by the manual line finder operation do not have a slip logo.

12 lines are fed by the manual line finder operation.			
KEY ENTRY	POST-BILL is used as CHECK-OUT BILL		
12	1 Served by CLERK NAME 00001		*1
BUFFER PRINT 1 --- *2	2		logo is printed by [SF-83.d]
	3	CUSTOMER	
	4	5#	
	5	PB.P	0.00
	6	BANANA CAKE	1.25
	7	TEA	0.80
	8	Today chag	2.05
	9	N.B	2.05
	10	QUANTITY	2
	11	JUL19/2003#001-000024 15:42R CLERK NAME 00001	
	12	Served by CLERK NAME 00001	*2 logo is not printed
		CUSTOMER	
		5#	
		PB.P	2.05
		ICE CREAM	2.00
		Today chag	2.00
		CASH	4.05
		QUANTITY	1
		JUL19/2003#001-000025 15:55R CLERK NAME 00001	

### 32. Ticket System

If the ECR is programmed for the ticket system [SF-1.b], all items will be ticket items. When items are registered, tickets are issued depending on one of three ticket issue types (real-time, after closing, mixed ticket) by [SF-3.g,h]. Then, when the transaction is closed, a post-receipt is issued by [SF-2.b].

**A PLU can be programmed to either of following two types by [PF-3.f];**

Ticket Item	1 to 7 tickets can be issued for an item independently by flag selection [PF-3.b,c,d].
Combined Item	Items are printed on one ticket.

**There are following ticket issue types to be selected by [SF-3.g,h];**

Real-Time Ticket	<ul style="list-style-type: none"><li>- Ticket items are printed in real-time and one combined ticket is printed after transaction closing.</li><li>- Multiple ticket can be issued by X1 key. (available for real-time ticket only)</li></ul>
After Closing Ticket	One ticket is issued containing all ticket items in real-time, then remaining number of tickets and one combined ticket are issued after transaction closing.
Mixed Ticket	Two kinds of combined ticket are printed.

#### Ticket Print Contents

Ticket header 1	printed on the first combined ticket of "after closing ticket" or "mixed ticket" by [SF-3.f]
Ticket header 2	printed on a combined ticket which is printed after closing transaction by [SF-3.f]
Consecutive ticket #	printed in double-width by [SF-2.a], centered by [SF-4.b]
Ticket number per item	separate from the consecutive ticket number is printed to distinguish 2 to 7 tickets for an item
Track number	printed in brackets < Item Track > or << Amount Track >>
Table number	printed in brackets * Table # *

#### Paper Cutting Method

This is fixed to a full cut between tickets.

### a) Real-Time Ticket Sample

Ticket items printed in real-time for programmed number of tickets.

```

[5-LINE LOGO]
                JUL07/2003
* . . . 5 *   <.....1>
SALAD                                5.00
                                         0001
#001-000001                            16:10R
                CLERK NAME 00001      1
    
```

#### REAL-TIME TICKET

\* table number \* in double-width, < item track number > in normal character

consecutive ticket number (printed by [SF-2.a], centered if [SF-4.b])  
 ticket number per item

```

----- full cut -----
                JUL07/2003
* . . . 5 *   <.....1>
SALAD                                5.00
                                         0001
#001-000001                            16:10R
                CLERK NAME 00001      2
    
```

no logo printed on the 2nd ticket

same consecutive ticket number is printed for 1st & 2nd tickets of two-ticket item  
 ticket number per item

```

[5-LINE LOGO]
                JUL07/2003
* . . . 5 *   <.....1>
STEAK                                10.00
                                         0002
#001-000001                            16:10R
                CLERK NAME 00001      1
    
```

```

----- full cut -----
                JUL07/2003
* . . . 5 *   <.....1>
STEAK                                10.00
                                         0002
#001-000001                            16:10R
                CLERK NAME 00001      2
    
```

```

[5-LINE LOGO]
                JUL07/2003
BAR
* . . . 5 *   <.....1>
BEER                                  2.50
WINE                                  3.00
                                         0003
#001-000001                            16:10R
                CLERK NAME 00001
    
```

#### COMBINED TICKET

printed after closing  
 ticket header 2 (printed by [SF-3.f])

#### POST-RECEIPT

```

[5-LINE LOGO]
                JUL07/2003
< . . . . . 1 > * . . . 5 *
Served by      CLERK NAME 00001
BEER                                2.50
WINE                                3.00
SALAD                                5.00
STEAK                                10.00
CASH                                20.50
                QUANTITY              4
#001-000001                            16:10R
                CLERK NAME 00001
    
```

salad & steak --- two-ticket item for food  
 beer & wine --- combined item for drink

Receipt consecutive #s are not printed on the tickets under clerk interrupt system.

For example,

- 1) After a customer orders at a table, the clerk enters the order into ECR.
- 2) The clerk brings the item tickets for food to the kitchen and the combined ticket for drink to the bar.
- 3) When the orders are prepared, the cook puts the 1st ticket in the "completed order box" and the 2nd ticket with the dish. Then the clerk carries them with the tickets to the customer's table. The tickets are used for the clerk's confirmation, for internal management, etc.

**b) After Closing Ticket Sample**

All ticket items are printed on the first combined ticket in real-time (a), then the remaining number of tickets (b) and original combined ticket items are printed on the second combined ticket (c).

```

[5-LINE LOGO]
      JUL07/2003
KITCHEN
SALAD          5.00
STEAK         10.00
              0004
#001-000002   16:15R
      CLERK NAME 00001
    
```

**1st COMBINED TICKET (a)**

ticket header 1 (printed by [SF-3.f])

consecutive ticket number (printed by [SF-2.a], centered if [SF-4.b])

---- full cut -----

```

      JUL07/2003
SALAD          5.00
              0005
#001-000002   16:15R
      CLERK NAME 00001  1
    
```

**2nd ticket of two-ticket item (b)**

no logo printed

These tickets are printed after closing.

ticket number per item

---- full cut -----

```

      JUL07/2003
STEAK         10.00
              0006
#001-000002   16:15R
      CLERK NAME 00001  1
    
```

**2nd ticket of two-ticket item (b)**

---- full cut -----

```

      JUL07/2003
BAR
BEER          2.50
WINE         3.00
              0007
#001-000002   16:15R
      CLERK NAME 00001
    
```

**2nd COMBINED TICKET (c)**

ticket header 2 (printed by [SF-3.f])

**POST-RECEIPT**

```

[5-LINE LOGO]
      JUL07/2003
Served by    CLERK NAME 00001
BEER          2.50
WINE          3.00
SALAD         5.00
STEAK        10.00
CASH          20.50
              QUANTITY  4
#001-000001  16:10R
      CLERK NAME 00001
    
```

salad & steak --- two-ticket item for food  
 beer & wine --- combined item for drink

Receipt consecutive #s are not printed on the tickets under clerk interrupt system.

For example,

- 1) The clerk brings the 1st combined ticket and 2nd item tickets for food to the kitchen and the 2nd combined ticket for drinks to the bar.
- 2) When the orders are prepared, the cook puts the 2nd ticket with the dish and crosses the item out on the 1st combined ticket. Then the clerk carries the dish with the ticket to the customer's table.
- 3) When all dishes are prepared, the 1st combined ticket goes into the "completed order box".

**c) Mixed Ticket Sample (two kinds of combined ticket)**

The number of tickets programmed for ticket item is ignored and ticket items are printed on the first combined ticket (a). Original combined ticket items are printed on the second combined ticket (b) after a transaction closing.

```

[5-LINE LOGO]
JUL07/2003
KITCHEN
SALAD          5.00
STEAK         10.00
#001-000003    0008
                16:16R
CLERK NAME 00001
    
```

**1st COMBINED TICKET (a)**

ticket header 1 (printed by [SF-3.f])

consecutive ticket number (printed by [SF-2.a], centered if [SF-4.b])

```

----- full cut -----
JUL07/2003
BAR
BEER          2.50
WINE         3.00
#001-000003    0009
                16:16R
CLERK NAME 00001
    
```

**2nd COMBINED TICKET (b)**

printed after closing, no logo printed  
ticket header 2 (printed by [SF-3.f])

Receipt consecutive #s are not printed on the tickets under clerk interrupt system.

**POST-RECIEPT**

```

[5-LINE LOGO]
JUL07/2003
Served by CLERK NAME 00001
BEER          2.50
WINE         3.00
SALAD         5.00
STEAK        10.00
CASH          20.50
QUANTITY      4
#001-000003    16:16R
CLERK NAME 00001
    
```

salad & steak --- two-ticket item for food (Two-ticket item settings are disregarded.)  
beer & wine --- combined item for drink

**d) Multiple Ticket Sample**

The multiple ticket is issued by entering the number of tickets and pressing **X1** key. This function is operative only when **real-time ticket issue** and **ticket PLU** have been selected. The number of tickets programmed will be ignored.

**OPERATION**

enter number of tickets --- **X1** --- enter ticket PLU

[5-LINE LOGO]		
JUL07/2003		
ADMISSION		5.00
#001-000004	0010	16:17R
CLERK NAME 00001		
----- full cut -----		
[5-LINE LOGO]		
JUL07/2003		
ADMISSION		5.00
#001-000004	0011	16:17R
CLERK NAME 00001		
----- full cut -----		
[5-LINE LOGO]		
JUL07/2003		
ADMISSION		5.00
#001-000004	0012	16:17R
CLERK NAME 00001		

consecutive ticket number (printed by [SF-2.a], centered if [SF-4.b])

Receipt consecutive #s are not printed on the tickets under clerk interrupt system.

***POST-RECEIPT***

[5-LINE LOGO]		
JUL07/2003		
Served by	CLERK NAME 00001	
3 X 5.00	ADMISSION	15.00
CASH		15.00
	QUANTITY	3
#001-000004		16:17R
CLERK NAME 00001		

## e) Other Notes for Ticket

### TICKET OFF key

If **TICKET OFF** key is pressed at the beginning of a transaction, the following registered ticket items will become a normal registration for one transaction.

### PLU with link PLU, Simple condiment PLU

Link PLU/Simple condiment PLU is printed on the same ticket of the main PLU. The ticket setting for the link PLU/Simple condiment PLU belongs to the main PLU.

### Track/Table #

Track/Table # should be entered at the beginning of a transaction to print it on the ticket.

	on ticket	on post-receipt
< item track # >	printed in normal character and centered	in double-width character and left justified
<< amount track # >>	printed in double-width and left justified	in normal character and left justified
* table # *	printed in double-width	in double-width

### Automatic post-receipt after ticket issue

- The automatic post-receipt is issued or is not issued after ticket issue by [SF-2.b].
- In the receipt-off condition, the post-receipt is issued by **BUFFER PRINT** key.
- In the receipt-off condition, if the "automatic slip print" [SF-83.g] has been selected (and a paper has been inserted for TP-620), the post-receipt is issued automatically on a slip.
- "Automatic receipt of track" can be programmed by [SF-1.a]. So if you would like to prohibit only receipt issue after ticket issue for a track, set [SF-1.a=1] and [SF-2.b=0].

### Ticket printed on kitchen printer --- this function is independent from the ticket system.

Separately from ticket printing on the receipt, if "ticket printed on KP" is programmed by [SF-112.c], tickets are printed on KP having a header of the kitchen printer.

If the ticket system [SF-1.b] is also programmed, tickets are printed on KP and receipt. By PLU programming [PF-5.g,h], you can control whether or not to print certain ticket items on KP/receipt printer.

Ticket can be printed on internal KP (ticket with KP header printed on receipt printer) if [SF-106.a~h=1].

### Notes.

- Normal KP function is **not** available.
- "Ticket printed on KP" [SF-112.c] function never has an automatic receipt after KP ticket issue but it always has a receipt at real-time. So if you wish to prohibit a real-time receipt issue when "ticket printed on KP" function is used, set the following flags:
  - [SF-1.b=1] Ticket System
  - [SF-2.b=1] Automatic receipt prohibited after ticket issue
  - [SF-112.c=1] Ticket printed on KP
  - [PF-5.g=1] This ticket item is printed on KP
- If you wish to prohibit a real-time receipt issue for a track only when "ticket printed on KP" function is used, set [SF-2.b] to 0 and set [SF-1.a] to 1.
- Tickets on KP do not have ticket headers, consecutive ticket number and ticket number per item.
- Simple Condiment PLU is printed in double-height characters with main PLU on KP.
- Link PLU is printed with a link PLU symbol with a main PLU, like on the receipt.
- Multiple ticket entry by **X1** key is not available.

### **33. Customer File**

1024 customer files make records of telephone number or VAT number, name and address - these information are issued on the receipts for delivery service market, etc. In order to use this function, an optional memory board is required.

#### **Customer File Data Structure**

PHONE # or VAT #	max.15 characters
CUSTOMER NAME	max.24 characters
ADDRESS 1	max.24 characters
ADDRESS 2	max.24 characters
ADDRESS 3	max.24 characters
LAST ACCESS DATE	mmddyyyy or ddmmyyyy [SF-7.e]

#### **Contents of This Section**

- a) New Customer File Making in R or SP Position
- b) Customer File Editing in SP Position
- c) Customer File Deleting in SP Position
- d) Customer File Pick-Up Sequence
  - < Customer File Pick-Up Before Registration >
  - < Customer File Pick-Up During Registration >
  - < Picked Up Customer File Cancellation in R Position >
  - < Customer File Pick-Up Methods >

**a) New Customer File Making in R or SP Position**

```
< R or SP >--[CUSTOMER FILE]--{ENTER PHONE/VAT#: max. 15 characters}--[ENTER/TTL 25]--
--{Warn Message #60: Customer file not found}--{MAKE NEW FILE ?}--[ENTER/TTL 25]--
--{ENTER NAME: max. 24 characters --[ENTER/TTL 25] or [ENTER/TTL 25] for skip name entry}--
--{ENTER ADDRESS 1~3: max. 24 characters --[ENTER/TTL 25] or [ENTER/TTL 25] for skip address
entry}--{ARE YOU SURE ?}--[ENTER/TTL 25] to make or [CL] to cancel}--(New customer file made.)

When Customer File is made in R position, after the sequence completed, a confirmation receipt is printed.
You can see the programmed customer's information on X-74 Customer File report.
```

**b) Customer File Editing in SP Position**

```
< SP >--[CUSTOMER FILE]--{ENTER PHONE/VAT#: max. 15 characters --[ENTER/TTL 25] or
just press [ENTER/TTL 25] to find customer file by using [SCROLL DOWN]}--{Customer File displayed}--
--{[00] to print confirmation receipt (can be skipped)}--[ENTER/TTL 25] to select Customer File}--
--{ENTER NAME/ADDRESS 1~3: max. 24 characters --[ENTER/TTL 25] or [ENTER/TTL 25] for skip}--
--{ARE YOU SURE ?}--[ENTER/TTL 25] to finish or [CL] to cancel}
```

**c) Customer File Deleting in SP Position**

```
< SP >--[CUSTOMER FILE]--{ENTER PHONE/VAT#: max. 15 characters --[ENTER/TTL 25] or
just press [ENTER/TTL 25] to find customer file by using [SCROLL DOWN]}--{Customer File displayed}--
--{[00] to print confirmation receipt (can be skipped)}--[VOID]--{DELETE is displayed}--
--{[ENTER/TTL 25] to execute deletion or [CL] to cancel}
```

In order to delete Customer File all together, take Z1/P-74 CUSTOMER FILE report.

**d) Customer File Pick-Up Sequence**

**< Customer File Pick-Up Before Registration >**

When customer file is picked up before registration, a customer confirmation is printed on the receipt.

Customer file can be picked up by entering the programmed phone number or VAT number. In order to find the customer file from the display, just press **ENTER** or **TTL 25** without entering the phone/VAT number. Then find the customer by using **SCROLL UP/DOWN** keys.

<p>KEY ENTRY</p> <p>CUSTOMER FILE</p> <p>63537021</p> <p>ENTER or TTL 25 -- to pick up</p> <p>ENTER or TTL 25 -- to define</p> <p>Continue registration.</p>	<p>CONFIRMATION RECEIPT</p> <table border="1"> <tr> <td> <p>DAVID SMITH</p> <p>5-25 3-chome Tenma</p> <p>Kita-ku Osaka</p> <p>JAPAN</p> <p>6353-7021</p> <p>#001-000001</p> <p>CLERK NAME 00001</p> </td> <td> <p>11:47R</p> </td> </tr> </table>	<p>DAVID SMITH</p> <p>5-25 3-chome Tenma</p> <p>Kita-ku Osaka</p> <p>JAPAN</p> <p>6353-7021</p> <p>#001-000001</p> <p>CLERK NAME 00001</p>	<p>11:47R</p>	<p>name (centered)</p> <p>address 1</p> <p>address 2</p> <p>address 3</p> <p>phone # or VAT #</p>
<p>DAVID SMITH</p> <p>5-25 3-chome Tenma</p> <p>Kita-ku Osaka</p> <p>JAPAN</p> <p>6353-7021</p> <p>#001-000001</p> <p>CLERK NAME 00001</p>	<p>11:47R</p>			

< Customer File Pick-Up During Registration >

There are two formats of customer confirmation receipt with normal receipt by programming when customer file is picked up during registrations. Also current total amount is printed on customer confirmation by programming. When customer file is picked up before registrations, the customer confirmation receipt only is printed.

```

KEY ENTRY
(registration)

CUSTOMER FILE
63537021
ENTER or TTL 25 -- to pick up
ENTER or TTL 25 -- to define

CASH
    
```

Receipt with customer confirmation (type-2)  
[SF-4.c=1]

```

*****
*           Your           *
*         Receipt         *
*       Thank You        *
*****
                JUL03/2003
RED WINE                7.00
WHITE WINE              8.00
CASH                    15.00
-----
AMONT                   15.00
                DAVID SMITH
                5-25 3-chome Tenma
                Kita-ku Osaka
                JAPAN
                6353-7021
-----
#001-000001                11:47R
                CLERK NAME 00001
    
```

\* total amount (key/symbol #37) printed by [SF-4.d]

Receipt and customer confirmation separately (type-1)  
[SF-4.c=0]

```

*****
*           Your           *
*         Receipt         *
*       Thank You        *
*****
                JUL03/2003
RED WINE                7.00
WHITE WINE              8.00
CASH                    15.00
#001-000001                11:47R
                CLERK NAME 00001
-----
*****
*           Your           *
*         Receipt         *
*       Thank You        *
*****
                JUL03/2003
AMONT                   15.00
                DAVID SMITH
                5-25 3-chome Tenma
                Kita-ku Osaka
                JAPAN
                6353-7021
#001-000001                11:47R
                CLERK NAME 00001
    
```

automatic cut

\* name (centered)  
address 1  
address 2  
address 3  
phone # or VAT #

< Picked Up Customer File Cancellation in R Position >

Customer file cancellation can be done when the customer file is picked up **during** registrations by pressing **CORRECTION** key.

< Customer File Pick-Up Methods >

For example, Phone # 81-6-6353-7021 or VAT # PH-237.69.98	You can pick up by entering the numbers below;	
A) You can enter the numbers as they were programmed.	81-6-6353-7021	PH-237.69.98
B) You can omit letters except alphanumeric.	81663537021	PH2376998
C) If the phone #/VAT # entered includes letters other than alphanumeric and there are no required file corresponding to, it automatically searches for the file corresponding to the phone #/VAT # by only alphanumeric letters. If there is simply no file corresponding to the phone #/VAT #, it will be registered as a NEW FILE. This prevents files having two identical numbers from existing.	81-66353-7021	PH-2376.9.98

< Note for Customer File Assignment to Item Tracks >

Once a customer file is assigned to an item track, the customer information is always printed on subtotal and check-out bills. Customer file assignment is **not** memorized on the amount track.

### 34. *ESF Data Print (optional memory board required)*

All registrations performed in the **R position** only are recorded in the ESF memory on the optional memory board if "ESF function available" [SF-78.a] has been programmed. The recorded data can be printed in the R position or the X position by **ESF PRINT** key on receipt by entering the print numbers below:

PRINT #	ESF data print contents
no number	last 5 transactions
<b>1</b>	last "n" transactions (n = 1 ~ 99)
<b>2</b>	transactions selected by "zone" (date, time, date & time)
<b>3</b>	transactions selected by "consecutive receipt numbers"
<b>4</b>	transactions of "minus operations" (transactions include minus amount or minus PLU quantity are printed)
<b>5</b>	transactions of "void & refund" including scroll void, transaction void
<b>6</b>	transactions of "correction"
<b>10</b>	transactions selected by "clerk"
<b>99</b>	all ESF data ( <b>X position only</b> )

Before printing ESF data, you can check how many records in the ESF memory have been used by taking **X-79** ESF status report. One record is printed approximately in one line. Please be sure that you are not taking **Z-79** report that will erase the ESF memory contents.

If programmed by [SF-78.c], **Z-79** ESF status report is printed with all ESF data.

#### ESF Data Print (not printed on journal)

```

*****
*                                     *
*      SAMPLE HEADER MESSAGE         *
*                                     *
*****
                        JUL25/2003
-----
transaction data
last line
date
      :
      :
      :
transaction data
last line
date
-----
#001-000005                    11:03R
                        CLERK NAME 00001
    
```

← ESF data print mark

← ESF data print mark

The consecutive # is always printed in normal character. Consecutive #s of the transaction data in ESF data print are printed in double-width character by [SF-7.b=1].

## ESF Data Print Sequences

### Last 5 transactions (no PRINT #)

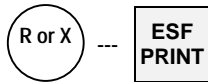

### PRINT #1: Last "n" transactions



### PRINT #2: Transactions selected by "zone" (date, time, date & time)

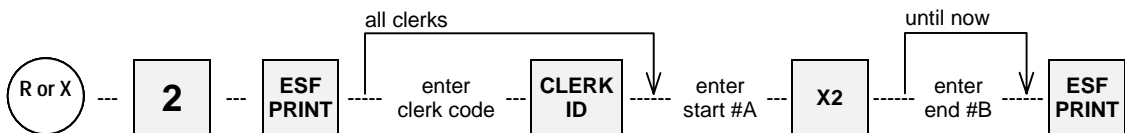

- < start #A > enter "date" or "date & time" or "time only (for today's transactions)"
- < end #B > enter "date" or "date & time" or "time only (for transactions between start date (& time) and the today's)

**Format of Date & Time**

Check date printed on a receipt for the date format.  
 date --- mmddyyyy or ddmmyyyy  
 date & time --- mmddyyyyhhmm or ddmmyyyyhhmm  
 time --- hhmm

### PRINT #3: Transactions selected by "consecutive receipt numbers"

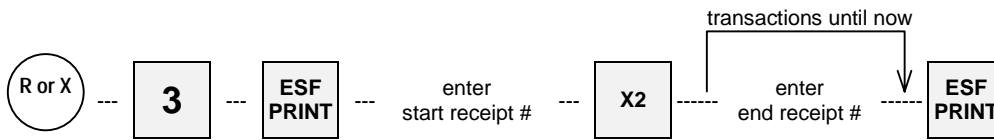

### PRINT #4: Transactions of "minus operations"

### PRINT #5: Transactions of "void & refund"

### PRINT #6: Transactions of "correction"

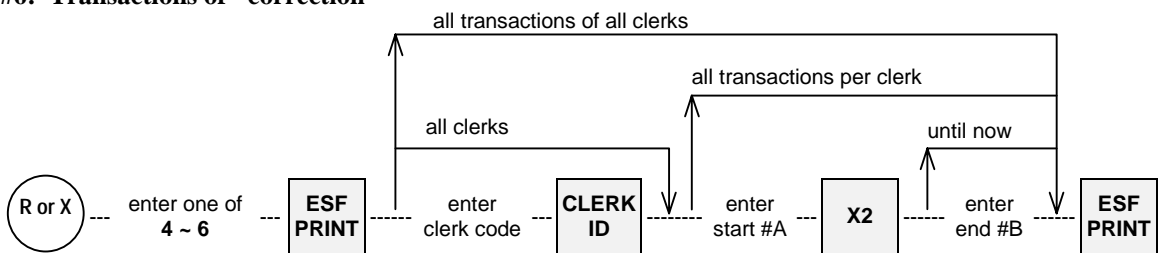

See above PRINT #2 for "start #A", "end #B", date and time formats.

### PRINT #10: Transactions selected by "clerk"



### PRINT #99: All transactions (X position only)

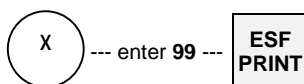

### 35. Cash Declaration

At the end of the day, confirm the cash in drawer amount using 'cash declaration'. A cash declaration receipt shows any discrepancies between the amount of cash that is supposed to be in the drawer and what is actually there is issued.

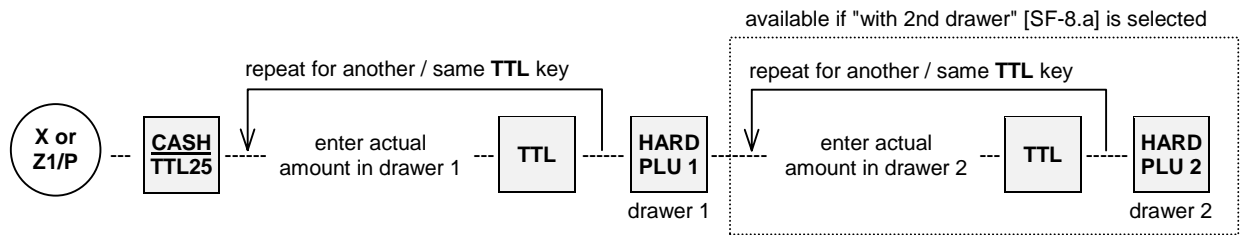

Even if the Cash Declaration is done at the Z1/P position, the CID amount is **not** reset. It will be reset by Z-08 CID report.

KEY ENTRY	RECEIPT		
CASH/TTL 25	CASH	30.00	actual amount in drawer 1
3000 CASH	TOTAL	30.00	
H. PLU 1	CID	30.00	amount in CID 1 memory
		0.00	difference

Media multiplication is available for PRESET TENDER keys.

## VII. TRAINING

Training mode is used for teaching ECR operations without affecting the memories of normal transactions, tracks and programming. In the training mode, reports can not be issued and ECRs can not initiate communication with other machines. However, except during a transaction, the memory of an ECR in the training mode can still be accessed by other ECRs in the IRC system.

### Entering the training mode

"TRAINING" message is displayed once and "T" is indicated at left below on the front display and the REG lamp on the rear display flashes continuously during the training.

Entering the training mode automatically signs off the currently signed-on clerk. Perform clerk sign-on to begin training.

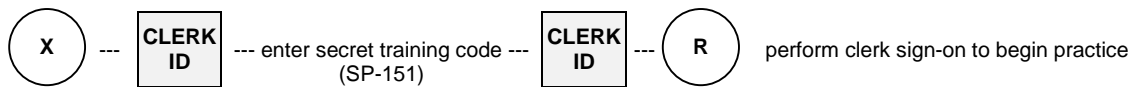

### Exiting the training mode

Exiting the training mode automatically signs off the currently signed-on clerk.

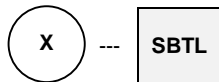

<p>KEY ENTRY (Entering training mode) &lt; X &gt; CLERK ID training code CLERK ID</p> <p>&lt; R &gt; CLERK 1 STEAK BEER CASH</p>	<p style="text-align: center;">"TRAINING" message is displayed once and "T" is indicated at left below.</p> <div style="border: 1px solid black; padding: 5px; margin: 10px 0;"> <p style="text-align: center;">RECEIPT</p> <p>***** TRAINING *****</p> <table style="width: 100%; border-collapse: collapse;"> <tr><td>STEAK</td><td style="text-align: right;">15.00</td></tr> <tr><td>BEER</td><td style="text-align: right;">2.50</td></tr> <tr><td>CASH</td><td style="text-align: right;">17.50</td></tr> <tr><td style="text-align: center;">QUANTITY</td><td style="text-align: right;">2</td></tr> </table> <p>***** TRAINING *****</p> <p>#001-000500 13:13R</p> </div> <p style="text-align: right; margin-right: 20px;">training message</p> <div style="border: 1px solid black; padding: 5px; margin: 10px 0;"> <p style="text-align: center;">SLIP</p> <p style="text-align: center;">***** TRAINING *****</p> <p>Served by CLERK NAME 00001</p> <table style="width: 100%; border-collapse: collapse;"> <tr><td>STEAK</td><td style="text-align: right;">15.00</td></tr> <tr><td>BEER</td><td style="text-align: right;">2.50</td></tr> <tr><td>CASH</td><td style="text-align: right;">17.50</td></tr> <tr><td style="text-align: center;">QUANTITY</td><td style="text-align: right;">2</td></tr> </table> <p style="text-align: center;">***** TRAINING *****</p> <p>JUL17/2003#001-000500 13:13R CLERK NAME 00001</p> </div> <p style="text-align: right; margin-right: 20px;">training message</p>	STEAK	15.00	BEER	2.50	CASH	17.50	QUANTITY	2	STEAK	15.00	BEER	2.50	CASH	17.50	QUANTITY	2
STEAK	15.00																
BEER	2.50																
CASH	17.50																
QUANTITY	2																
STEAK	15.00																
BEER	2.50																
CASH	17.50																
QUANTITY	2																

**Notes for the training mode**

- A programmable training message is printed on the journal, receipts, validations and slips.

VALIDATION (SLIP)

*****	TRAINING	*****	13:13	CASH	17.50
-------	----------	-------	-------	------	-------

- The consecutive number is not incremented.
- The training mode has its own track memory separate from the regular track memory. The memory is erased when exiting the training mode.
- Training count, amount and training grand total (GX) are printed on the transaction reports (01 ~ 04). Training grand total, GX, is printed after grand totals G1 and G2. GX includes the amounts of all transactions done in the training mode, and is not resettable.

FULL TRANSACTION REPORT

X-03			
2	T-AMT	3	16.87
	NSALE	3	
	PERSN	3	
	TRCNT	11	
	TIP		8.00
	CID		140.03
2	N.B		12.25
1	PB.P		5.76
	Net-charge		6.45
	G1:00000000000000000000		183.37
	G2:00000000000000000000		183.37
	GX:00000000000000000000		16.87
	X-0007		
#001-000154			19:20X
	CLERK NAME	00001	

training count, amount (key/symbol #15)  
 grand total 1  
 grand total 2  
 training grand total

## VIII. PRINT CONTENTS

---

### 1. Journal Print Contents

Either the normal journal contents or selective journal contents can be printed by programming [SF-6.c]. Also, if programmed by [SF-6], the messages for power-off/-on times, initial reset times and cleared figures (with \* symbols) can be printed on the journal. Furthermore, there is journal saving format by [SF-3.d].

<b>Normal Journal Contents</b>	exactly the same way as the receipt contents are printed and logo is printed by [SF-2.g,h]
<b>Selective Journal Contents</b>	only the tax line and media closing lines are printed by [SF-6.c]

### 2. Receipt / Slip Print Contents

Besides the transaction items, the following items are printed on the receipt and slip. Printed position of the contents might vary whereas the printed contents are the same.

- 5-line receipt upper logo [SF-6.e], (graphic logo [SF-10.d], 5-line slip upper logo [SF-83.d])
- date [SF-7.e,f]  
English month name: mmmdd/yyyy or ddmmm/yyyy, Numeric month name: mm/dd/yyyy or dd/mm/yyyy
- message (if entered)
- PLU name, PLU price
- PLU supplementary message (printed above a PLU name)
- cooking message (printed under a PLU name)
- PLU code (printed by [SF-68.h], double-width character by [SF-7.a])
- PLU link group-A name [SF-68.e]
- amount due (normal or double-width character by [SF-7.d], double-height/width by [SF-3.c])
- media (one blank line is inserted by [SF-5.b])
- tax data [SF-22]
- item quantity [SF-6.d]
- number of people (if entered)
- last line: 3-digit machine #, 6-digit consecutive receipt # (normal/double-width character [SF-7.b]), 2-digit clerk symbol by [SF-11.a], time [SF-7.h for receipt/journal, SF-83.c for slip], control mode & clerk name
- 5-line receipt lower logo [SF-10.e], 5-line slip lower logo [SF-86.d] (not available for TP-620)

### 3. Post-Receipt

When the ECR is in the receipt-off condition and the ECR is **not** programmed for use with a slip printer, the last transaction's data can be printed by pressing **BUFFER PRINT** key after closing the transaction. If the ECR is programmed for use with a slip printer, the post-receipt is printed on the slip.

Addition to Post-Receipt, Second Receipt is printed by **BUFFER PRINT** key if permitted by programming [SF-1.d] and when the ECR is **not** programmed for use with a slip printer.

PROGRAMMED AS	RECEIPT-ON	RECEIPT-OFF
Second Receipt permitted	1 receipt + 1 second receipt by <b>BP</b> key *	1st post-receipt by <b>BP</b> key 2nd post-receipt by <b>BP</b> key *
Second Receipt prohibited	1 receipt + no second receipt	1 post-receipt by <b>BP</b> key

\* Second receipt message is printed by [SF-8.g] under the date.

JUL19/2003	
* COPY *	
Served by	CLERK NAME 00001
PLU-NAME 00001	1.00

second receipt message  
(key/symbol #65)

## ***IX. REPORTS***

---

### ***REPORT SEQUENCE***

#### **Control Key Position**

Set the control key to **X, Z1 or Z2 position** and use the report sequence below;

- 1st level for daily report: X (read only) position or Z1 (reset) position
- 2nd level for periodic report: X (read only) position or Z2 (reset) position

For Z report issue and report format, there are some programming restrictions. Refer to system function flags [SF-26~29] and the clerk security function flags.

#### **Report Selection Method**

User friendly sequence is possible with usability of LCD display as follows:

1. Turn the control key to X position.
2. Enter the clerk ID and press **CLERK ID** key.
3. Select REPORT and press **ENTER** key.
4. Select the report from the list by **ENTER** key.  
If you know the report number, enter the report number and press **X2** key.
5. Press **ENTER** or **TTL 25** to issue the report.

#### **Direct Number Entry Method**

If you are familiar with the conventional report sequences which have been used by the conventional series, this method is much faster than "Report Selection Method" to enter into the report sequence.

1. Turn the control key to X position.
2. Enter the report number, for example "1" for X-01 AUTO FULL TRANSACTION - 1st level report.
3. Press **X2** key.
4. Press **ENTER** or **TTL 25** to issue the report.

## Report Sequence

<p><b>Full Report</b></p> <p>&lt;X or Z&gt;--(report #)--[X2]--[ENTER/TTL 25]  or {select from the list}--[ENTER/TTL 25] or {select FULL REPORT and press [ENTER/TTL 25]}</p>
<p><b>Individual Report</b></p> <p>&lt;X or Z&gt;--(report #)--[X2]--(*required #)--[ • ]--[TTL 25]  or {select from the list}--{select INDIVIDUAL REPORT}--(*required #)--[ • /ENTER]--[TTL 25]</p>
<p><b>Sequential Report</b></p> <p>&lt;X or Z&gt;--(report #)--[X2]--(*start #)--[X2 ([ITEM TRACK #] for #78 Customer Bill report)]--(*end #)--  [ENTER/TTL 25] or {select from the list}--{select SEQUENTIAL REPORT}--(*start #)--[X2 ([ITEM  TRACK #] for #78 Customer Bill report)]--(*end #)--[ENTER/TTL 25]</p>

### \* required #, start/end #

Clerk report	Enter the sequential clerk number (not 4-digit clerk code) for clerk reports.
Group report	Enter the group number.
PLU report	Scanner can be used to enter PLU code. Before entering PLU code, MENU SHIFT/PLU MODIFIER keys can be pressed if required.
Track report	Enter the track number.
Customer file report (#74)	Enter date (mmddyyyy or ddmmyyyy) indicated on full customer file report. It is printed in "order of customer file programmed" or "descending order of last access date if sorted by the sequence below. Customer File Sort Sequence: <X>--[CUSTOMER FILE] Display  Sort completed. total number of customer files After the customer file is sorted, the order will not be returned.
Customer bill report (#78)	(78)-[X2]--(start item track #)--[ITEM TRACK #]--(end item track #)-- [ENTER/TTL 25] (78)-[X2]--(start date or date & time or time)--[X2]--(start date or date & time or time)--[ENTER/TTL25] date: mmddy or ddmmyyyy [SF-7.f] Check date format on the front display. date & time: mmddyyyyhhmm or ddmmyyyyhhmm time: hhmm If you specify time only, it is considered as today's time.
Function program dump report (#85)	Refer to the table shown on <a href="#">page 114</a> .

TRANSACTION REPORT	REPORT #		REPORT SEQUENCE		
	1st level (X / Z1)	2nd level (X / Z2)	Full	Individual	Sequential
Auto Full Transaction	1	2	o		
Full Transaction ( <b>X position</b> only)	X-3	X-4	o		
Hourly	5	6	o		
Grand Total 1	---	7	o		
Cash In Drawer	8	---	o		
EFT Terminal Data Transfer & Reset ( <b>Z position</b> only) See note below.	Z1-9	---	o		
Clerk	10	11	o	o	
Specified 20 PLUs / Group-A Sales per Clerk [SF-12.c]	---	12	o	o	
Specified 1000 PLU Sales per Clerk *	---	13	o	o	
Time & Attendance *	19	---	o	o	
Main Group-A	20	21	o		
Group-A per Main Group-A	22	23	o	o	
Group-A	25	26	o	o	
Group-A Stock	---	27	o		
Group-B	30	31	o	o	
PLU	40	41	o	o	o
PLU Stock	---	42	o	o	o
Non-Active PLU ( <b>X position</b> only)	X-43	X-44	o		
Menu 1 PLU ( <b>X position</b> only)	X-50	X-51	o		
Menu 2 PLU ( <b>X position</b> only)	X-52	X-53	o		
Menu 3 PLU ( <b>X position</b> only)	X-54	X-55	o		
Group-A PLU	56	57	o	o	
Group-B PLU	58	59	o	o	
Item Track Total ( <b>X position</b> only)	X-60	---	o	o	o
Item Track (set [SF-29.a] for Z report)	62	---	o	o	
Clerk Item Track ( <b>X position</b> only)	X-64	---	o	o	
Amount Track Total ( <b>X position</b> only) *	X-65	---	o	o	o
Amount Track (set [SF-29.a] for Z report) *	66	---	o	o	
Clerk Balance	70	---	o	o	
Customer File (files are erased by Z report) *	74	---	o		o
Customer Bill [SF-78.h=1] *	78	---	o		o
ESF Status (issued only when [SF-78.a=1], [d=1] for Z79, ESF data printed if [c=1]) * ESF data printed by ESF PRINT key.	79	---	o		

\* optional memory board required

**Note for Z1-9 EFT Terminal Data Transfer & Reset Report**

By issuing Z1-9 report, the data in the EFT terminal is transferred to the host terminal and the data is cleared. This report is not available when Celectronic terminal is used by [SF-66.f~h].

Set the control key to **X position** for all program dumps except for clerk dump.

PROGRAM DUMP	REPORT #	REPORT SEQUENCE		
		Full	Individual	Sequential
Full Program	80	o		
Main Group-A	81	o		
Group-A	82	o		
Group-B	83	o		
Key Layout	84	o		
Function	85	o	o (see table below)	
Key & Symbol Name	86	o		
Tax	87	o		
PLU	88	o		o
Clerk ( <b>Z2 position</b> )	Z2-89	o		
Menu Layout	90	o		
Hard Clerk Key	94	o		
Clerk PLU / Group-A Assignment	95	o		
Communication Setting	99	o		

**Required # for Individual Function Program Dump (X-85)**

#	Report Contents
1	system function flag
2	media currency symbol, media name, foreign currency exchange rate, media function flag, preset tender key amount
3	number of programmed PLUs, PLU modifier value
4	terminal address
5	slip printer ID number
10	clerk name
20	% rate
21	discount amount
22	plus amount
23	adjustment rate
24	cheque-cashing/currency exchange rate, Euro currency exchange rate
25	PLU sales commission rate
26	PLU stock rate, stock unit name
27	tare weight 1 ~ 99
40	arrangement key sequence
41	cheque printing data

## ***IRC REPORT SEQUENCE***

### **Collecting Transaction Data from Slaves**

There are two kinds of IRC reports issued by the master ECR:

- One is a **consolidated report** for all ECR's sales data and
- the other is an **individual report**, by designating the slave ECR by using the sequence below;

Set the control key to **X, Z1 or Z2 position**.

- 1st level for daily report : X (read only) position or Z1 (reset) position
- 2nd level for periodic report : X (read only) position or Z2 (reset) position

#### **Consolidated (all ECRs) Report**

<X or Z>--(report #)--[X2]--[ENTER/TTL 25] or {select ALL ECRs from the list}--[ENTER/TTL 25]

#### **Individual (per ECR) Report**

<X or Z>--(report #)--[X2]--(slave ECR machine #)--[ENTER/TTL 25]

or {select from the list}--{select slave ECR from the list}--[ENTER/TTL 25]

The master ECR can collect the slave ECR's sales data only when the slave ECR is in an idle condition (no other communication, no transaction). When the slave ECR is transmitting sales data to the master, the display shows " --- **IRC COMM** ---" and ECR locks until IRC communication stops.

The following IRC reports are printed on the master and slave ECRs respectively.

'IRC Z report printed or not printed' [SF-29.b] can be programmed also.

		<b>Master prints</b>	<b>Slave prints</b>
<b>Consolidated X-report</b>		a consolidated report	a confirmation report on journal only
<b>Individual X-report</b>		a designated slave's report	a confirmation report on journal only
<b>Consolidated Z-report</b>	printed [b=0]	own report and a consolidated report with IRC status	own report
	not printed [b=1]	own confirmation report and a consolidated report with IRC status	a confirmation report on journal only
<b>Individual Z-report</b>	printed [b=0]	a designated slave's report with IRC status	own report
	not printed [b=1]	a designated slave's report with IRC status	a confirmation report on journal only

IRC REPORT	REPORT #		REPORT SEQUENCE		
	1st level (X / Z1)	2nd level (X / Z2)	All ECRs consolidated	Per ECR individual	
Auto Full Transaction	8801	8802	o	o	
Hourly	8805	8806	o	o	
Grand Total 1	---	8807	o	o	
Cash In Drawer	8808	---	o	o	
Clerk	8810	8811	o	o	
Specified 20 PLU/Group-A Sales per Clerk	---	8812	o	o	
Main Group-A	8820	8821	o	o	
Group-A	8825	8826	o	o	
Group-A Stock	---	8827	o	o	Note 1
Group-B	8830	8831	o	o	
PLU	8840	8841	o	o	
PLU Stock	---	8842	o	o	Note 1
Item Track	8862	---	*	o	
Clerk Item Track (X position only)	X-8864	---	*	o	
Amount Track	8866	---	*	o	
Clerk Balance	8870	---	*	o	
ESF Status [SF-78.a=1] (optional memory board required)	8879	---	*	o	Note 2

\* The consolidated reports are not available for these reports. However, if PC communication module Tensai2000 is used as an IRC master, you can take individual report from all ECRs at one time. In order to have the consolidated report data, add the individual report data together on PC.

In addition to all of above reports, you can take **Time & Attendance (8819)** and **Specified 1000 PLU Sales per Clerk (8813)** reports by Tensai2000.

Note 1: **Consolidated Z report:** the stock of slave ECRs is added to master ECR's stock memory and cleared to zero.  
**Individual Z report:** the stock of designated slave ECR is **not added** to master ECR's stock memory but it is cleared.  
**Both reports do not clear** the master ECR's stock memory. Issue Z-27/42 reports on the master to clear.

Note 2: To issue ESF report 8879, "ESF function available" [SF-78.a=1] should be set on both of master and slave ECRs. When this individual report is taken, the slave's ESF data is always transmitted to the master.  
**X-8879:** the master prints ESF status but the slave IRC status only.  
**Z-8879:** the master always prints ESF status only. The slave prints ESF status and if [SF-78.c=1] is set, the ESF data is printed with ESF status on the slave.

## FLASH IRC REPORTS

Flash **read-only** reports as shown below can be issued at any time on the master ECR by using the following sequences in **X** position only. The flash report will not disturb the slave ECR even when the slave ECR is in transaction, report issuing or programming sequence.

Flash report is printed on the master ECR with IRC status. No message will be displayed and X-report will not be counted up for a flash report on a slave ECR. If the flash report can not be taken from a slave ECR, the IRC status "slave ECR's machine number and NG" are printed on the master ECR.

### Consolidated (all ECRs) Report

< X >--{(report #)--[X2] or select from the list}--{(required #)--[ • ] or select from the list}--[ENTER/TTL 25]

### Individual (per ECR) Report

< X >--{(report #)--[X2] or select from the list}--{(required #)--[ • ] or select from the list}--{(slave ECR machine #) or select from the list}--[ENTER/TTL 25]

	FLASH IRC REPORT #		REQUIRED #
Transaction	8601 (1st level)	8602 (2nd level)	See Table below.
Hourly	8605 (1st level)	8606 (2nd level)	one of time zone 0 ~ 23
Grand Total 1	8607		no number required
Cash In Drawer	8608		no number required
Clerk	8610 (1st level)	8611 (2nd level)	one of clerk sequential #1 ~ 64
Main Group-A	8620 (1st level)	8621 (2nd level)	one of main group-A #1 ~ 10
Group-A	8625 (1st level)	8626 (2nd level)	one of group-A #1 ~ 98
Group-A Stock	8627		one of group-A #1 ~ 98
Group-B	8630 (1st level)	8631 (2nd level)	one of group-B #1 ~ 25
PLU	8640 (1st level)	8641 (2nd level)	one of PLU code
PLU Stock	8642		one of PLU code
Clerk Item Track	8664		one of clerk sequential #1 ~ 64

Required #s and Contents for X-8601/8602			
1	amount/count of media in sales	13	amount/count of new balance of Item Track amount/count of charge of Amount Track (option)
2	amount/count of media in drawer & rounding error	14	amount/count of cheque-cashing, currency exchange
3	taxable sales & tax amounts	15	amount/count of training
4	amount/count of %	17	no sale count
5	amount/count of (-) discount	18	number of people
6	amount/count of (+) plus	20	transaction count
7	amount/count of adjustment	21	tip amount
8	amount/count of P/O	22	amount/count of PLU correction
9	amount/count of R/A	27	amount/count of positive previous balance for Item Track and Amount Track (option)
10	amount/count of void	28	amount/count of negative previous balance for Item Track and Amount Track (option)
11	amount/count of refund	29	net charges for Item Track and Amount Track (option)
12	amount/count of transaction void		

**Note for X-8610 Clerk :** This is printed with X-8664 Clerk Item Track flash IRC report if programmed by [SF-28.b].

### Note for X-8664 Clerk Item Track

Number of tracks per ECR printed on this report is limited to **19~21\*** when the clerk interrupt system and/or Automatic Track # Method is used, or **21** when non-clerk interrupt system and Manual Track # Method are used. (\*Area for two tracks are occupied by table #.) If a clerk has more than 19~21 tracks, "ECR machine # --->" mark is printed on the report. However, always up to 17 tracks can be printed by the master ECR.

# TRANSACTION REPORT SAMPLES

## AUTO FULL TRANSACTION (01, 02)

Consists of two separate reports, Group-A (25, 26) and Full Transaction (03, 04). Refer to each report for details.

X-01	
	Group-A report
-----	
	Full transaction report

Depending on programming [SF-26, 27], issuing the Z-01 or Z-02 report will reset to zero any of the following data on each report where the data appears: Cash in Drawer, Consecutive Receipt/Ticket Number, X Report Count and Grand Total 1.

## FULL TRANSACTION (03, 04)

X-03	
SALES TTL	
1	F.C. MEDIA 0.95
1	EURO 10.00
10	CASH 140.03
TOTAL 150.98	
AVRG	12.58
DRAWER TTL	
1	CHEQUE 17.50
1	F.C. MEDIA
10.5425 *	0.95
	£9
1	EURO
1.97719 *	10.00
	5.06
10	CASH 140.03
TOTAL 167.53	
	< 0.00 >
A	
TXSL1	55.62
TXSL2	18.75
TOTAL	74.37
TAX 1	1.11
TAX 2	0.75
TOTAL	1.86
V	
TXSL3	17.48
TOTAL	31.36
TAX 3	0.52
TOTAL	0.64
1	% 1 0.20
1	DSCNT 0.60
1	PLUS 0.60
1	AJST1 0.60
1	AJST2 0.60
1	P/O 5.00
1	R/A 10.00
1	VOID 1.00
1	REFND 3.00
1	T.VOID 5.00
1	CORRECTION 1.00
1	CHEQUE 0.60
2	T-AMT 16.87
NSALE	3
PERSN	3
TRCNT	11
TIP	8.00
CID	140.03
CID2	0.00
3	N.B 38.00
1	PB.P 7.00
1	PB.N 1.00
Net-charge	32.00
2	CHARGE 10.00
1	PB.P2 5.00
1	PB.N2 1.00
N.CHARGE	6.00
G1:0000000000000000183.37	
G2:0000000000000000183.37	
GX:000000000000000016.87	
X-0007	
#001-000154	19:20X
CLERK NAME 00001	

### Media Amount in Sales

media count, name, amount  
calculated Euro amount in local currency

average sales per person (sales amount divided by number of people entered in transactions)

### Media Amount in Drawer

foreign currency exchange rate, calculated local currency media amount  
media amount in foreign currency

Euro currency rate, actual amount in Euro currency (Euro currency symbol is printed if [SF-65.b=0].)  
temporarily calculated amount in local currency by actual amount in Euro currency

rounding error: arises because of difference when calculating back and forth for a currency exchange rate

**Symbol A** for tax calculated by Add-on Tax method (printed if [SF-26.a=1])  
taxable subtotal amount

total taxable subtotal  
tax amount

total tax amount

**Symbol V** for tax calculated by VAT method

Either accumulated or re-calculated VAT amount at report taking can be selected by [SF-30.d].  
When "VAT amount re-calculated at report" is selected, VAT amount on the IRC report is calculated either by each slave ECR or by master ECR can be selected for the consolidation report by [SF-30.e].

count and amount of: %  
amount discount

amount plus

adjustment 1

adjustment 2

P/O

R/A

void

refund

transaction void

PLU correction (printed if [SF-68.f=1])

cheque-cashing, currency exchange

training count, amount (key/symbol #15)

no sale count

number of people

transaction count

tip amount

cash amount in drawer 1

cash amount in drawer 2 ([SF-8.a])

Item Track/PB operation: new balance count, amount (printed if [SF-27.g=0])

Item Track/PB+ operation: previous balance positive count, balance (printed if [SF-27.g=0])

Item Track/PB- operation: previous balance negative count, balance (printed if [SF-27.g=0])

Item Track/PB operation: net-charge -- total amount of non-closed item track

Amount Track (option): charge count, amount (printed if [SF-27.g=0])

Amount Track (option): previous charge positive count, balance (printed if [SF-27.g=0])

Amount Track (option): previous charge negative count, balance (printed if [SF-27.g=0])

Amount Track (option): net-charge -- total amount of non-closed amount track

grand total 1

grand total 2 (not resettable)

training grand total (not resettable)

X-report count

machine #, consecutive #, time & mode

clerk name

**Media Amount in Sales**

Amount sold in each media. This amount does not include no sale transactions (P/O, R/A, cheque-cashing, etc.) and results of rounding.

**Media Amount in Drawer**

Actual amount in drawer. This amount includes no sale transactions (P/O, R/A, cheque-cashing, etc.) and results of rounding. When no sale transactions are done, the amounts will be added to the memory, but the media count will not be changed.

Differences between media amount in sales and media amount in drawer arise when payment is in one media and change is in another or as a result of rounding. For example, a customer gives a 100.00 cheque for a 60.00 charge. Change is 40.00 in cash. Then, media amount in sales adds 60.00 to cheque memory. Media amount in drawer adds 100.00 to cheque memory and subtracts 40.00 from cash memory.

**Foreign Currency Media Amount in Drawer**

When a media has been used for a foreign currency, the media in drawer memory stores the foreign currency value. The printed local currency amount is temporarily calculated by the memorized foreign currency value. The difference between the actual sales amount and the calculated local currency amount arises because of the difference when calculating back and forth for a currency exchange rate. This difference is printed under the total amount, within brackets < >.

For example, when a sales amount of 1.00 (decimal point is disregarded on calculation) is closed by a **F.C. MEDIA** key which has a preset exchange rate of 10.5425\*,

\* This exchange rate is calculated by "LC / FC". The calculation method "FC / LC" is also available by [MF-1.h].

1. Foreign currency is calculated by dividing the due amount 1.00, in local currency, by the exchange rate 10.5425.

Local Currency to Foreign Currency :

$LC / \text{exchange rate} = 100 / 10.5425 = 9.4854... = \text{rounded to } \mathbf{9}$  (printed on the receipt)

At the same time, the FC amount 9 is converted to LC amount 95 (9 x 10.5425) and the difference **.05** between the actual sales 1.00 and the calculated LC amount .95 is stored in the rounding error (difference) memory and will be printed within brackets < > on the sales report.

2. The printed local currency amount **.95** on the report is calculated from the memorized foreign currency **9**.

$FC \times \text{exchange rate} = 9 \times 10.5425 = 94.8825 = \text{rounded to } \mathbf{95}$

**Tax**

Printed by [SF-26.a]. When using the VAT system, the taxable subtotal can be programmed not to include tax by [SF-22.c]. When using the add-on tax system, the taxable subtotal does not include tax. If programmed, adjustment, %, plus and discount calculations will affect each taxable subtotal.

**Tip**

Total amount of all clerk' tips. Tip will also be added to a media memory by [SF-29.f].

**Cash in Drawer Amount**

Total of the media in drawer amounts that are programmed to be added to CID.

**New Balance**

The amount closed by **NB** key for Item Track and PB+/PB- operations. Includes tax and percentage calculations if tax and percentage are calculated on closing by **NB** key ([SF-16.g]). This amount does not reset to zero after the Item Track or PB+/PB- operation is closed by a media key.

**Previous Balance Plus**

The count is the total number of times that an Item Track was opened when the previous balance was either zero or positive and a PB+ key was used. The amount is the accumulation of positive previous balances that were picked up when an Item Track was opened and an amount was entered by PB+ operations.

**Previous Balance Minus**

The count is the total number of times that an Item Track was opened and a PB- key was used.

The amount is the accumulation of negative previous balances that were picked up when an Item Track was opened and an amount was entered by PB- operations.

**Net Charge**

Net charge shows the total amount of all non-closed transactions. It is calculated from the new balance and the previous balances.



**CASH IN DRAWER (08)**

Total of the media in drawer amounts is printed if media are programmed to be added to CID memory by [MF-1.a].

X-08		
CID	140.03	
CID2	0.00	[SF-8.a]

Actual media amount which is manually entered in cash declaration sequence is printed on X/Z-08 CID report by [SF-27.b=1].

X-08		
CHECK	0.00	Even when the actual media amount is not manually entered in cash declaration sequence, zero media amount is printed.
CUPON	0.00	
UC	0.00	
TTL4	0.00	
TTL5	0.00	
TTL6	0.00	
TTL7	0.00	
TTL8	0.00	
TTL9	0.00	
TTL10	0.00	
TTL11	0.00	
TTL12	0.00	
TTL13	0.00	
TTL14	0.00	
TTL15	0.00	
TTL16	0.00	
TTL17	0.00	
TTL18	0.00	
TTL19	0.00	
TTL20	0.00	
TTL21	0.00	
TTL22	0.00	
TTL23	0.00	
TTL24	0.00	
CASH	140.03	actual media amount entered in cash declaration sequence printed by [SF-27.b]
TOTAL	140.03	
CID	140.03	CID amount
:	0.00	difference between actual amount in drawer and CID memory

**EFT TERMINAL DATA TRANSFER & RESET (Z1-09)**

By issuing Z1-9 report, the data in the EFT terminal is transferred to the host terminal and the data is cleared. This report is not available when Celectronic terminal is used by [SF-66.f~h].

## CLERK (10, 11)

X-10			
C01	CLERK NAME 00001		
13		71.60	
AVRG	7.16		
S1	0 %	71.60	
S2	5 %	0.00	
S3	10 %	0.00	
S4	15 %	0.00	
TOTAL		71.60	
CM		0.00	
TIP		0.00	
1	VOID	2.00	
2	REFND	1.15	
1	T.VOID	3.50	
NSALE	1		
CLEAR	5		
CORRECTION	0		
PERSN	10		
DRAWER TTL			
:			
TOTAL		28.41	
		< 0.00 >	
1	P/O	2.00	
2	R/A	1.15	
CID		4.64	
-----			
ALTTL		71.60	
S1		71.60	
S2		0.00	
S3		0.00	
S4		0.00	
ALTTL		71.60	
VOID		2.00	
REFUND		1.15	
T.VOID		3.50	
-----			

sequential clerk number, clerk name  
 transaction count, amount  
 average sales per person (sales amount divided by number of people entered)  
 sales commission 1 ~ 4 rate, amount  
 total amount of sales-type 1 ~ 4 PLUs ([SF-28.e-h])  
 total amount of commission  
 tip amount  
 void count, amount  
 refund count, amount  
 transaction void count, amount  
 no sale count  
 clear count  
 correction count  
 person count  
 media in drawer count, amount (same contents as X-03 full transaction report)  
 total media amount  
 rounding error  
 P/O count, amount  
 R/A count, amount  
 cash in drawer amount

all clerk's total transaction amount  
 total amount of each sales-type 1 ~ 4 PLU  
 total amount of sales-type 1~ 4 PLUs  
 void amount  
 refund amount  
 transaction void amount

X-11			
C01	CLERK NAME 00001		
13		71.60	
AVRG	7.16		
CM		0.00	
TIP		0.00	
PERSN	10		
-----			
ALTTL		71.60	
-----			

sequential clerk number, clerk name  
 transaction count, amount  
 average sales per person (sales amount divided by number of people entered)  
 total amount of commission  
 tip amount  
 person count

all clerk's total transaction amount

Note: On the full report, some data with value of "0" will be skipped by [SF-28.a]. On individual report, it is skipped by [SF-28.c].

### Sales-Type 1 ~ 4 PLU Amount

All PLUs are categorized by sales-type 1 ~ 4 [PF-1.c,d]. With a four-type clerk memory, the sales amounts of type-1 ~ 4 PLUs are listed separately from each clerk's transaction amount.

The sales-type 1 ~ 4 PLU amounts include the discount, plus and % amount on item by [SF-29.e]. These amounts on subtotal and adjustment amounts are always not included in the sales-type 1 ~ 4 PLU amounts. Also, when using the VAT system, the PLU amount can be programmed to include tax by [SF-27.c]. When using the add-on tax system, the PLU amount does not include tax.

### Total Amount of Commission

Commission amount is calculated by the sales-type 1 ~ 4 of each PLU by four respective commission rates. Only the total amount will be printed on the report.

The ECR does not have 1st level memory for commission.

On the 1st level report, the commission is calculated by each sales-type when the report is issued. When the Z-report of 1st level clerk is issued, the commission is accumulated in the 2nd level.

On the 2nd level report, the commission is calculated from the temporary 1st level amount plus the 2nd level memory amount.

### Cash In Drawer Amount

The media in drawer amounts per clerk that are programmed to be added to CID by [MF-1.a].

**SPECIFIED 20 PLU/GROUP-A SALES PER CLERK (12)**  
**SPECIFIED 1000 PLU SALES PER CLERK (13)** -- optional memory board required

This report is used to check who sold the specified PLUs or group-A assigned by SP-214 ([SF-12.c]) and SP-224.

```

X-12
C01
  CLERK NAME 00001
P-----1#
  PLU-NAME 00001
    17                16.85
    :
```

sequential clerk number  
clerk name  
PLU code  
PLU name  
sales quantity, amount

Notes:

- PLUs are printed by the assigned order.
- All data whether "0" valued or not is printed on X/Z-12 report. "0" valued data is skipped on X/Z-13 report.

**CLERK TIME & ATTENDANCE (19)** -- optional memory board required

```

X-19
  1#
  CLERK NAME 00001
JUL10/2003 08:50   J01
..... 17:40   08:50
JUL11/2003 08:51   J01
..... 17:35   08:44
JUL12/2003 21:55   J01
JUL13/2003 05:33   07:38
JUL15/2003 08:48   J02
..... 17:45   08:57
JUL16/2003 08:51   J01
..... 17:38   08:47
JUL17/2003 08:45   J02
-----/-----  ---:--
  J01      33.98
  J02      8.95
```

4-digit clerk code  
clerk name  
time-in date and time, job number  
time-out time, labor hour (time-out date is not printed if it is the same day as time-in)  
  
time-out date and time  
  
8 hours + (57 min./60 min.) = 8.95 hours  
You can calculate his payment by "8.95 x pay amount".  
  
time-out operation is not performed yet  
total labor hours per job

Note: If Z-19 report is taken, time-out date & time is automatically set, and calculated labor hour is printed with the automatic time-out symbol \*.

## MAIN GROUP-A (20, 21)

This report shows the ten main group-A's which are used to monitor sales of all drinks, all snacks, all daily goods, etc. Each main group-A consists of linked group-A's.

X-20			
17	MAIN GP-01 32.692%	16.85	main group-A quantity, name, amount sales % (printed by [SF-27.e])
:			
<b>TOTAL</b>		119.15	total amount

### Main Group-A Quantity

It is always calculated by item quantity.

### Sales %

Each group's % of total sales is calculated either by quantity of items sold or by sales amount ([SF-27.h]). A positive sales % is calculated from the total positive sales and a negative sales % is calculated from the total negative sales.

## GROUP-A PER MAIN GROUP-A (22, 23)

This report shows the linked group-A's per main group-A.

X-22			
MG 01	MAIN GP-01		main group-A number, name
17	GROUP-A-01	16.85	linked group-A quantity, name, amount
100 %			sales % per main group-A (printed by [SF-27.e], calculated by [SF-27.h])
<b>TOTAL</b>		16.85	total amount per main group-A
-----			
:			
<b>ALTTTL</b>		119.15	total amount of all Main Group-As

### Linked Group-A Quantity

The quantity is calculated either by stock rate or by item quantity [SF-68.c].

## GROUP-A (25, 26) / GROUP-B (30, 31)

X-25			
17	GROUP-A-01	16.85	group quantity, name, amount
	MAIN GP-01		link main group-A name (only for group-A)
32.692%			sales % (printed by [SF-27.e], calculated by [SF-27.h])
:			
<b>TOTAL</b>		119.15	total amount of all groups

### Group-A or B Quantity

Only Group-A quantity is calculated either by stock rate or by item quantity ([SF-68.c]). Group-B quantity is always calculated by item quantity.

### Group-A or B Amount

Group-A/B amount is calculated as:

total PLU amount linked to each group-A/B  
 %, (+), (-) amount on item ([SF-29.e])  
 +) VAT tax amount

## GROUP-A STOCK (27)

This report shows the total stock of PLUs which are linked to group-A. The stock is calculated either by item quantity or calculated quantity using stock rate by [SF-68.c].

X-27	
GROUP-A-01	15.5
GROUP-A-02	7.5
:	

group-A name, total stock of PLUs linked to group-A

## PLU (40, 41)

X-40	
P-----1#	
PLU-NAME 00001	
GROUP-A-01	
16	16.00
1	0.85
-----	
17	16.85
17.0 kg	
:	
-----	
TOTAL	119.15

PLU code  
 PLU name  
 link group-A name  
 1st price PLU quantity, amount  
 2nd price PLU quantity, amount (not printed when sales at 2nd price is 0 by [SF-8.b=1])  
 total of 1st & 2nd prices PLU quantity, amount (not printed if [SF-8.b=1])  
 sales quantity calculated by stock rate (printed if PLU has a stock rate [PF-2.b-d]), stock unit name is printed by [SF-6.a])  
 all PLUs' total amount

### PLU Amount

PLU amounts include the discount, plus and % amounts on item ([SF-29.e]).

Discount, plus and % amounts on subtotal and adjustment amounts are never included in the PLU amounts.

### Sales Quantity Calculated by Stock Rate

This quantity is calculated by each PLU's stock rate ([SF-68.c]). For example, if the stock rate is "0.2 (litter)" and the sold quantity is 3, the sales quantity will be 0.6 (litter).

## PLU STOCK (42)

This report shows the stocks of PLU that remain. The stock is calculated either by item quantity or calculated quantity using stock rate ([SF-68.c]).

X-42	
P-----1#	
PLU-NAME 00001	17.0 kg

PLU code  
 PLU name, stock (calculated by item quantity or by stock rate)  
 stock unit name is printed by [SF-6.a]

## NON-ACTIVE PLU (43, 44)

This report shows PLU items (PLU code and name) that have not been sold.

## MENU 1 ~ 3 PLU (50 ~ 55)

These reports show sales data for PLU assigned to each menu on the keyboard. The report contents are the same as PLU report.

There is no original memory for each menu in PLU memory. The content of report is getting its sales information from the same one PLU memory, so if you are using the same PLU in each menu, the result of total number of each PLU is the same in each menu report.

### GROUP-A PLU (56, 57) / GROUP-B PLU (58, 59)

This report shows the consolidated PLU sales data of items which are linked to a group-A or a group-B. The report contents are almost the same as PLU report.

X-56		
GA 01	GROUP-A-01	
P-----1#		
PLU-NAME	00001	
17		16.00
2		0.85
-----		
17		16.85
17.0	kg	
100	%	
<b>TOTAL</b>		16.85
-----		
<b>ALTTL</b>	:	119.15

Each group name  
 PLU code (linked to group-A or B)  
 PLU name  
 1st price PLU quantity, amount  
 2nd price PLU quantity, amount  
 total of 1st & 2nd prices PLU quantity, amount  
 sales quantity calculated by stock rate ([SF-68.c])  
 sales % per group (printed by [SF-27.f], calculated by [SF-27.h])  
 total amount per group  
 all group's total amount

### ITEM TRACK TOTAL (60)

Shows the total balance amount of temporarily closed Item Tracks by New Balance key. When Item Tracks are closed by a media key, the data is updated by subtracting the track amounts from the total.

X-60	
<b>TOTAL</b>	12.00

total balance due of all tracks

### ITEM TRACK (62)

Shows each amount of temporarily closed Item Tracks by New Balance key. The table number is printed if entered.

X-62		
<	5> *-----*	
	CLERK NAME 00001	5.00
<	6> *-----*	
	CLERK NAME 00001	7.00
<b>TOTAL</b>		12.00

< item track number >, \* table number \*  
 assigned clerk name, balance due  
 total balance due of all item tracks

### CLERK ITEM TRACK (64)

Shows each amount of temporarily closed Item Tracks per clerk. The table number is printed if entered.

X-64		
CLERK NAME	00001	
<	5> *-----*	5.00
<	6> *-----*	7.00

clerk name  
 < track number >, \* table number \*, balance due

**AMOUNT TRACK TOTAL (65) -- Optional memory board required.**

Shows the total balance amount of all temporarily closed Amount Tracks by CHARGE key. When Amount Tracks are closed by a media key, the data is updated by subtracting the track amounts from the total.

X-65	
TOTAL	12.00

total balance due of all tracks

**AMOUNT TRACK (66) -- Optional memory board required.**

Shows each amount of temporarily closed Amount Tracks by CHARGE key.

X-66		
<< 101>>	CLERK NAME 00001	5.00
<< 201>>	CLERK NAME 00001	7.00
TOTAL		12.00

<< amount track number >>  
assigned clerk name, balance due

total balance due

**CLERK BALANCE (70)**

Shows each clerk balance that has been stored under the clerk interrupt system.

X-70		
< 01 >	*-----*	
	CLERK NAME 00001	5.00
< 02 >	*-----*	
	CLERK NAME 00002	7.00

< clerk sequential number >, \* table number \*  
clerk name, balance due in the clerk memory

Note: If an Item Track operation is done under the clerk interrupt system, the track is saved in the track memory (not in the clerk memory).

**CUSTOMER FILE (74) -- Optional memory board required.**

Customer file data is printed in "order of customer file programmed" or in "descending order of last access date (if sorted by <X>-[CUSTOMER FILE])". Z-74 report prints and erases all the customer file data.

X-74	
DAVID SMITH 5-25 3-chome Tenma Kita-ku Osaka JAPAN 81-6-6353-7021 (JUN07/2003)	name (max. 24 characters) --- centered address 1 (max. 24 characters) address 2 (max. 24 characters) address 3 (max. 24 characters) phone number/VAT number (max. 15 characters) last access date
----- : EDWARD Throstle St. Blackburn Lancashire England BB2 1TQ 44-1254-54546 (JUN08/2003)	

**CUSTOMER BILL (78) --** Optional memory board required.

Shows the historical record of the main details of all finalized item tracks. They do not include PLU contents. It is memorized in the customer bill memory by [SF-78.h].

X-78		
-----		
<.....1>		item track number
CASH	3.40	finalized amount
#001-000005	15:25R	last line information
CLERK NAME 00001		
JUL19/2003		date
-----		
<.....2>		
CASH	3.00	
TXSL1	2.73	
TAX 1	0.27	
#001-000006	15:26R	
CLERK NAME 00001		
JUL19/2003		
-----		
USED :	10	number of used records
REST :	3961	number of remaining records
ALLOT:	3971	total number of records

**ESF STATUS (79) --** Optional memory board required.

Each journal data is memorized in the ECR's ESF (Electronic Store & Forward) memory by [SF-78.a]. This report shows the ESF status. For Z-79 report, ESF status with all ESF data is printed by [SF-78.c] whereas ESF status report is prohibited by ECR (permitted only by PC) by [SF-78.d].

X-79		
USED :	524	number of used records
REST :	11391	number of remaining records
ALLOT:	11915	total number of records

Z-79 report prints and clears all the stored journal data.

Z-79		
-----		
PLU NAME-00000000001	1.00	} stored journal data (printed by [SF-78.c])
PLU NAME-00000000002	2.00	
CASH	3.00	
QUANTITY	2	
#001-000068	13.24R	
CLERK NAME 00001		
JUL18/2003		
NSALE	0.00	
#001-000069	13.24R	
CLERK NAME 00001		
JUL18/2003		
:		
-----		
USED :	524	
REST :	11391	
ALLOT:	11915	

## X. WARNING MESSAGES

---

The messages which are programmed by SP-182 will be displayed under certain specific conditions. In the auto preset condition, the default messages "WARN MESSAGE# xx" are displayed.

- WM-#1 PRINTER ERROR**  
Turn the power off and perform the initial reset operation.
- WM-#2 INPUT FIGURE OVER LIMITATION**  
Press **CL** key. (PLU HALO can be released temporarily by using **HALO RELEASE** key)  
It is displayed when total amount exceeds the amount limitation of EFT terminal.
- WM-#3 CLERK IS NOT SIGNED ON**
- WM-#4 ITEM OR MEDIA SLIP VALIDATION IS COMPULSORY**  
Print item or media slip validation by **MISC. (ITEM/MEDIA) VALIDATION** key.  
(can be released temporarily by using **OFF COMPULSORY** key)
- WM-#5 TOTAL SLIP VALIDATION IS COMPULSORY**  
Print total slip validation by **TOTAL VALIDATION** key.  
(can be released temporarily by using **OFF COMPULSORY** key)
- WM-#6,7 NOT USED**
- WM-#8 MESSAGE INPUT IS COMPULSORY**  
(can be released temporarily by using **OFF COMPULSORY** key)
- WM-#9 PERFORM FOREIGN CURRENCY SUBTOTAL DISPLAY OPERATION**  
Press **F.C. SBTL** key and **F.C. MEDIA** key.
- WM-#10 NUMBER OF PEOPLE INPUT IS COMPULSORY**  
(can be released temporarily by using **OFF COMPULSORY** key)
- WM-#11 SBTL KEY DEPRESSION IS COMPULSORY BEFORE TENDERED AMOUNT INPUT**  
(can be released temporarily by using **OFF COMPULSORY** key)
- WM-#12 TAX TABLE IS NOT PRESET**  
Enter tax amount manually. Preset tax table.
- WM-#13 TENDERED AMOUNT INPUT IS COMPULSORY**  
(can be released temporarily by using **OFF COMPULSORY** key)
- WM-#14 DRAWER IS OPEN**  
This message is displayed only when the factory optional 'drawer open sensor' is being used.
- WM-#15 CASH DECLARATION IS COMPULSORY**  
(can be released temporarily by using **OFF COMPULSORY** key)
- WM-#16 REGISTRATION BUFFER IS ALMOST FULL**  
Prepare to close the transaction.
- WM-#17 PLU STOCK IS ZERO OR NEGATIVE**  
Enter stock by programming. Displays only when [SF-70.h=1] is set.  
(can be released temporarily by using **HALO RELEASE** key)
- WM-#18 NOT USED**
- WM-#19 ECR TO ECR RAM DATA TRANSFER ERROR**  
Check the cable connection between ECR & ECR. Refer to INTERFACES & PERIPHERALS MANUAL for details.
- WM-#20 CLERK iBUTTON IS REMOVED**  
Insert previously removed clerk iButton.
- WM-#21 SLIP PRINTER IS BUSY**  
Press **CL** key and wait for the printer to be ready. TP-620: Press 'PRINT' on the printer to proceed with the slip.
- WM-#22 NOT USED**
- WM-#23 RECEIPT PAPER END**  
Replace with new paper roll.
- WM-#24 JOURNAL PAPER END**  
Replace with new paper roll.
- WM-#25 THERMAL PRINTER IS OVERHEATED**  
Please wait until the head cools down.
- WM-#26 THERMAL PRINTER HEAD IS RELEASED**  
Close the paper roll cover by pressing down the surbased point.
- WM-#27 SHORT TENDERING AMOUNT INPUT OF TTL 25 PROHIBITED**
- WM-#28 SIMPLE CONDIMENT PLU ENTRY IS PROHIBITED**  
Main PLU not entered yet.
- WM-#29 SIMPLE CONDIMENT PLU INPUT IS COMPULSORY**  
(can be released temporarily by using **OFF COMPULSORY** key)
- WM-#30 PLU NOT FOUND**  
Enter correct PLU code or program PLU code.

**WM-#31 CHECK-OUT BILL ISSUE IS COMPULSORY**

Press **CHECK-OUT BILL** key. (can be canceled by using **BILL CANCEL** key)

**WM-#32 SLIP PAPER HAS NOT BEEN INSERTED**

**WM-#33 CURRENT ITEM TRACK / CLERK INTERRUPT MEMORY IS FULL**

Close the item track or the clerk's transaction temporarily by **NB** (New Balance) key or close it by a **TOTAL** (media) key.

**WM-#34 ENTIRE ITEM TRACK / CLERK INTERRUPT MEMORY IS FULL**

Close the item track by **NB** (New Balance) key or the clerk's transaction temporarily by **STORAGE** or **NB** key, then:

- close another item track, or
- another clerk's transaction by a media key to secure additional item track / clerk interrupt memory, or
- do the previous balance key operation.

This message is also displayed when all item tracks are used under the limited automatic item track number.

**CHECKING THE NUMBER OF BLOCKS OF ITEM TRACK / CLERK INTERRUPT MEMORY**

This function is used for checking the number of remaining blocks.

- Set the control key to **X** position.
- Press **ITEM TRACK #** key.
- The number of remaining blocks is displayed.



number of remaining blocks (total 312 blocks)

After the item track or the clerk's transaction has been closed by a media key, the occupied blocks will become free. To secure the memory of currently occupied transactions, a new transaction can not be opened, even if a few blocks remain.

The maximum number of item tracks or clerk interrupt memories, that can be handled, depends on the number of items registered per item track or clerk interrupt memory.

**# of blocks**

- 312 blocks are available.
- One transaction always occupies one block.
- Up to 24 blocks (max. 359 items) are used for one transaction.
- 1st block can memorize 7 items, and 2nd ~ 24th blocks 16 items per block.

**# of item tracks/clerk interrupt memories** (max. 64 clerk interrupt memories)

- Up to 312 (max.) item tracks/clerk interrupt memories can be used if 7 items each is registered.
- Up to 150 item tracks/clerk interrupt memories can be used if 23 items each is registered.
- Up to 100 item tracks or clerk interrupt memories can be used if 39 items each is registered.
- Up to 50 item tracks or clerk interrupt memories can be used if 87 items each is registered.
- Up to 30 item tracks or clerk interrupt memories can be used if 151 items each is registered.
- Up to 13 item tracks or clerk interrupt memories can be used if 359 items (max.) each is registered.

For example, in case of 50 tracks:  $312 \text{ blocks} / 50 \text{ tracks} = 6.24 \text{ blocks/track}$ ,  $7 \text{ items (1st block)} + 5 \text{ blocks} * 16 \text{ items} = 87 \text{ items}$

**WM-#35 NEW BALANCE CLOSING OF ITEM TRACK IS COMPULSORY**

(can be released temporarily by using **OFF COMPULSORY** key)

**WM-#36 NEW BALANCE CLOSING OF ITEM TRACK IS PROHIBITED**

**WM-#37 ITEM TRACK # INPUT IS COMPULSORY**

**WM-#38 TABLE # INPUT FOR ITEM TRACK IS COMPULSORY**

**WM-#39 COOKING MESSAGE INPUT IS COMPULSORY**

(WM-#37~39: can be released temporarily by using **OFF COMPULSORY** key)

**WM-#40 ITEM / AMOUNT TRACK TRANSFER IS PROHIBITED**

**WM-#41 ITEM TRACK # NOT FOUND**

**WM-#42 SLIP PRINT IS COMPULSORY**

(can be released temporarily by using **OFF COMPULSORY** key)

**WM-#43 CLERK ID ERROR**

The clerk was not assigned to the track in registration. Enter correct clerk code or use the correct clerk key.

- WM-#44 SUBTOTAL BILL ISSUE COMPULSORY**  
(can be released by using **BILL CANCEL** key)
- WM-#45 ARE YOU SURE TO EXECUTE TRANSACTION VOID ?**
- WM-#46 CLERK IS BEING USED**  
Sign off the clerk in R position. Then sign on the clerk again in the appropriate control key position by entering clerk code and pressing **CLERK ID** key.  
(displayed when Z report or program sequence is performed during transaction)
- WM-#47 "SWIPE CARD" MESSAGE FOR MEDIA CLOSING BY CARD**
- WM-#48 PLU CODE CHECK DIGIT ERROR**  
Enter correct PLU code.
- WM-#49 PLU CODE PRICE CHECK DIGIT ERROR OF IN-STORE MARKING CODE**  
Enter correct PLU code.
- WM-#50 AMOUNT TRACK MEMORY IS FULL OR MEMORY NOT EXIST**  
(displayed when optional memory board has not been installed)
- WM-#51 AMOUNT TRACK # NOT FOUND**
- WM-#52 AMOUNT TRACK # INPUT IS COMPULSORY**  
(can be released temporarily by using **OFF COMPULSORY** key)
- WM-#53 CHARGE CLOSING OF AMOUNT TRACK IS COMPULSORY**  
(can be released temporarily by using **OFF COMPULSORY** key)
- WM-#54 CUSTOMER BILL MEMORY NOT EXIST**  
(displayed when optional memory board has not been installed)
- WM-#55 CUSTOMER BILL MEMORY IS NEAR FULL**
- WM-#56 CUSTOMER BILL MEMORY IS FULL**  
Take Z-78 Customer Bill report to reset customer bill memory.
- WM-#57~59 NOT USED**
- WM-#60 CUSTOMER FILE IS NOT FOUND**
- WM-#61 CUSTOMER FILE MEMORY IS FULL OR MEMORY NOT EXIST**  
Take Z-74 Customer File report to erase customer files.  
(displayed when optional memory board has not been installed)
- WM-#62 NOT USED**
- WM-#63 PREPARATIONS FOR EURO CONVERSION ARE NOT COMPLETED**  
[SF-54.e=1], Z1/P-397, SP-101
- WM-#64 ENTERED NUMBERS FOR EURO CONVERSION SEQUENCE IS NOT CORRECT**
- WM-#65 SCANNER COMMUNICATION ERROR**
- WM-#66~68 NOT USED**
- WM-#69 JOURNAL DATA TRANSFER BUFFER IS FULL**
- WM-#70 IRC LINE (RS485) IS BUSY**
- WM-#71 ECR IS IN COMMUNICATION WITH EFT TERMINAL**
- WM-#72 EFT TERMINAL COMMUNICATION ERROR**  
Press **CL** key.
- WM-#73 CARD DATA ABORTED BY EFT TERMINAL**
- WM-#74 ENTER VOUCHER NUMBER PRINTED ON A RECEIPT OF EFT TERMINAL**
- WM-#75 SLIP PRINTER ERROR**  
Confirm the setting of slip printer. Refer to INTERFACES & PERIPHERALS MANUAL for details.
- WM-#76 ENTER CORRECT CLERK CODE FOR TIME-IN OPERATION**
- WM-#77 TIME-IN OPERATION ALREADY DONE**
- WM-#78 TIME-IN OPERATION HAS NOT BEEN DONE YET**
- WM-#79 TIME & ATTENDANCE MEMORY IS FULL OR MEMORY NOT EXIST**  
Take Z-19 Time & Attendance report.  
(displayed when optional memory board has not been installed)
- WM-#80 ESF MEMORY IS FULL**  
Clear ESF data by issuing Z-79 report with data print by [SF-78.c], by taking Z-8879 by PC (from Tensai2000), or by taking Z-79 report by PC batch communication. See also MISCELLANEOUS MESSAGES "ESF NEAR FULL".
- WM-#81~88 KITCHEN PRINTER 1 ~ 8 ERROR**  
Confirm the setting of printers. Refer to INTERFACES & PERIPHERALS MANUAL for details.
- WM-#89 EFT TERMINAL IS OUT OF ORDER**  
Set "Storing EFT" for C-ZAM EFT terminal according to Dutch bank specification.
- WM-#90 COMMUNICATION TIME OUT**

- WM-#91 WEIGHT HAS NOT BEEN CHANGED (ITEM NOT REMOVED)**  
(displayed only when the scale has been programmed this way)
- WM-#92 NOT USED**
- WM-#93 TARE WEIGHT ENTRY IS OVER FLOW**
- WM-#94 TARE WEIGHT ENTRY IS COMPULSORY**  
(can be released temporarily by using **OFF COMPULSORY** key)
- WM-#95 MANUAL TARE WEIGHT ENTRY IS PROHIBITED**
- WM-#96 THIS PLU IS NOT SCALABLE PLU**
- WM-#97 SCALE COMMUNICATION ERROR / WEIGHT ERROR**  
Confirm the setting of scale. Refer to INTERFACES & PERIPHERALS MANUAL for details.  
Reduce the item on the scale or put the item if the weight display is zero. This is displayed if the item weight on the scale exceeds the limit weight of the scale or the item weight is zero when **SCALE** key is pressed.

## MISCELLANEOUS MESSAGES

<b>INITIAL RESET RQ</b>	SYSTEM ERROR : Since Initial Reset is required, perform the initial reset.
<b>IR DONE</b>	INITIAL RESET OPERATION ACCEPTED
<b>--- Pc comm ---</b>	IN PC BATCH COMMUNICATION
<b>PC comm error</b>	PC BATCH COMMUNICATION ERROR
<b>--- PC-IN ---</b>	RECEIVING RAM DATA FROM PERIPHERAL (ECR to ECR RAM data transfer)
<b>--- PC-OUT ---</b>	TRANSFERRING RAM DATA TO PERIPHERAL (ECR to ECR RAM data transfer)
<b>ESF NEAR FULL</b> displayed on the bottom line	<p>OPTIONAL ESF MEMORY IS NEAR FULL 11315 records out of maximum 11915 if customer bill function is used. 15287 records out of maximum 15887 if customer bill function is <u>not</u> used.</p> <p>The ESF memory near full condition can be cleared by issuing Z-79 report with data print by [SF-78.c], by taking Z-8879 by PC (from Tensai2000), or by taking Z-79 report by PC batch communication.</p> <p>When ESF memory becomes full, the data first stored, i.e. data at the starting of ESF memory area, will be deleted from ESF memory (only when [SF-78.b=0] is selected).</p>

## XI. IRC MESSAGES

Following messages are displayed on the master ECR or the slave ECRs in IRC communication:

Displayed on Slave ECR	
--- IRC COMM ---	Displayed on the top when a slave ECR is in IRC communication.

Displayed on Master ECR	
-- IRC BUSY --	Displayed on the top when a slave ECR is in IRC communication, or when the communication line is being used by other ECR for slip printer transmission, etc.
ECR-xxx ->	Displayed on the bottom when master ECR is in IRC communication of report collection or program download.
ECR#-xxx <-	Displayed in the floating track/clerk operation when master ECR requires a slave #xxx to send a track or clerk's data.
ECR-xxx OFF	Displayed while the master is taking IRC Z report when a slave #xxx is in error (can not communicate), or when the power is 'off,' or the cable being disconnected.
ECR#-xxx BUSY	Displayed when a slave #xxx is processing a transaction, or when a transaction is closed but some compulsory conditions still remain, or when the same track or clerk is used by the floating track/clerk operation.
ECR#-xxx ERROR	Displayed in the floating track/clerk operation when a slave #xxx is in error (can not communicate), or when the power is 'off,' or the cable being disconnected.

Floating Item Track	
REQ.Z62-xxx TTTTTTT	Displayed when a communication error occurs after receiving item track data from a slave #xxx. It requires to delete the track #TTTTTTT on the slave #xxx by Z-62 individual item track report. Because two tracks having same number will exist on the master and slave.
REQ.X62-xxx TTTTTTT	Displayed when master ECR can not check that the item track data is surely deleted from a slave #xxx. It requires to check the track #TTTTTTT on the slave #xxx by X-62 individual item track report.

Floating Amount Track	
REQ.Z66-xxx TTTTTTT	Displayed when a communication error occurs after receiving the amount track data from a slave #xxx. It requires to delete the track #TTTTTTT on the slave #xxx by Z-66 individual amount track report. Because two tracks having same number will exist on the master and slave.
REQ.X66-xxx TTTTTTT	Displayed when master ECR can not check that the amount track data is surely deleted from a slave #xxx. It requires to check the track #TTTTTTT on the slave #xxx by X-66 individual amount track report.

Floating Clerk	
REQ.Z70-xxx CC	Displayed when a communication error occurs after receiving the clerk's data from a slave #xxx. It requires to delete the data from the slave #xxx by Z-70 individual clerk balance report. Because two clerks' data will exist on the master and slave. CC shows a sequential clerk number.
REQ.X70-xxx CC	Displayed when master ECR can not check that the clerk's data is surely deleted from a slave #xxx. It requires to check the clerks' data on the slave #xxx by X-70 individual track report. CC shows a sequential clerk number.

xxx: slave ECR's machine number

## **POWER OFF / BUSY / COMMUNICATION ERROR AT SLAVE ECR**

For **X-report data**, the master ECR prints consolidated X report skipping power offed or busy slave ECR. See IRC status printed at the end of the report for non-consolidated slave ECRs.

When collecting **Z-report data** and one or more of the slave ECRs are not ready, the master ECR displays slave ECR status as shown above. Re-attempt to collect the slave's report or skip it.

### **TTL 25 key for re-attempt:**

If you wish to include an ECR's data on Z-report, close the transaction in process on that particular slave, or turn its power on and then press **TTL 25** key on the master ECR.

### **CL key for skip:**

If you do not wish an ECR's data on the report, press **CL** key and the master will skip that slave ECR. Master resumes data collection for the next ECR in the system.

## **POWER OFF AT MASTER ECR**

If the power fails while collecting **X-report data**, the master prints consolidated X report when the power returns. See IRC status printed at the end of the report for non-consolidated slave ECRs.

If the power fails while collecting **Z-report data**, the master ECR displays the machine number of the slave ECR when the power returns. Press **CL** key to skip or press **TTL 25** key to re-attempt.

## **REMOVING THE ERROR ECR DURING FLOATING TRACK/CLERK**

When ECR is in a communication error or power-off during the floating clerk/track operation, you can retry the floating operation by removing the error ECR from IRC system. Set the system function flag [SF-16.b] (ECR in IRC communication error during floating track/clerk system is removed from IRC system by TTL 25 key in X position).

**Sequence**            < X >---[ TTL 25 ]

When **TTL 25** key is pressed in X position, the error ECR is removed from IRC system. Then retry the floating clerk/track operation. In order to set the removed ECR into IRC system once again, perform IRC status check (SP/X-8800) again.

### **Note for Floating Clerk Data**

By adding this feature, the same clerk's data may exist on more than one ECR. In order to solve this situation:

1. Transfer the clerk's transaction data to an item track on ECR A.
2. Transfer the clerk's transaction data to an item track on ECR B with same track number of ECR A.
3. Perform Item Track Consolidation operation.  
Enter item track number to be consolidated -- [ NB ] -- [ TTL 25 ]